

Water Management Solutions







# Domestic Wastewater Control Panel User Manual

Kingspan Klargester 1011026



## Contents

1.	Health and Safety.....	3
1.1.	Health & Safety at Work, etc. ACT 1974 .....	3
2.	Declaration of Conformity .....	3
3.	General Description .....	3
4.	General Operation .....	3
5.	Applicable Firmware .....	3
6.	Technical Support .....	3
7.	Installation .....	4
7.1.	General Electrical .....	6
7.2.	General Installation.....	6
7.3.	Installation of Integral Discharge Pump (where applicable)  .....	6
7.4.	Installation of High-Level Alarm – HLA (where applicable)  .....	6
7.5.	Beacon units - P.No. 1009254 (where applicable)  .....	6
7.6.	For Biotec, Bioficient or BioSafe Applications.....	7
7.7.	For Biodisc Applications  .....	7
7.8.	Completing the Installation.....	8
7.9.	Ancillary Equipment.....	8
8.	Configuration Programming .....	8
8.1.	Start Up .....	8
8.2.	Detailed Operation.....	9
8.3.	Alarms .....	9
8.4.	Service.....	10
8.5.	Telemetry Relays Outputs.....	10
8.6.	Menu .....	10
9.	Technical Information.....	13
9.1.	Control Unit.....	13
9.2.	LED Beacon 1009254.....	14
10.	Default Timetables .....	15
10.1.	De-sludge Pump.....	15
10.2.	Motor/Blower .....	15
10.3.	Chemical Dosing Pump .....	15

# 1. Health and Safety

These warnings are provided in the interest of safety. You must read them carefully before installing or using the equipment.

It is important that this document is retained with the equipment for future reference. Should the equipment be transferred to a new owner, always ensure that all relevant documents are supplied in order that the new owner can become acquainted with the functioning of the equipment and the relevant warnings.

To ensure that the equipment described is safe both for personnel and property it should be installed, inspected, and maintained by or under the supervision of qualified persons (Electrician)

Covers must be kept locked. Observe all hazard labels and take appropriate action to avoid exposure to the risks indicated. Ensure that you are familiar with the safe working areas and accesses. Ensure that the working area is adequately lit.

The power supply to the equipment should be isolated at the main RCD before lifting the blower cover.

Take care to maintain correct posture, particularly when lifting. Use appropriate lifting equipment when necessary. Always keep proper footing and balance. Avoid any sharp edges.

## 1.1. Health & Safety at Work, etc. ACT 1974

Regard should be taken of IEE Wiring Regulations, Codes of Practice, Statutory Requirements, and any specific instructions issued by the supplier of these details.

Earthing - All equipment must be earth bonded in accordance with the latest IEE Wiring Regulations. For clarity this has not been shown.

We reserve the right to alter these details without prior notice.

# 2. Declaration of Conformity

This product meets all the essential safety requirements of the relevant European Directives.

The full text of the Declaration of Conformity can be provided upon request.

# 3. General Description

The DTP control Panel is used to control and monitor the Kingspan Klargester Domestic Wastewater Treatment Units. It is capable of operating multiple pump/motor outputs at set times in accordance with pre-determined timetables.

# 4. General Operation

The control unit continuously monitors the internal timetables and operates the appropriate pump/motor outputs according to a timetable entry. The status is shown on the display. The current time continues to be updated internally by battery backup when the mains fail, and the control unit continues normally upon mains being restored.

# 5. Applicable Firmware

The operation described in this manual refers to control units with the following firmware:

Firmware ID	Description	Version
FMW-1112	Kingspan 1002510	RV1.22

# 6. Technical Support

Technical support & **PIN** may be obtained from:

Kingspan Water & Energy – Service

College Road,

Aylesbury

HP22 5EW

Phone UK: 03332406868

Phone ROI: 04838362400

Or

Contact Kingspan Area Sales Manager

## 7. Installation

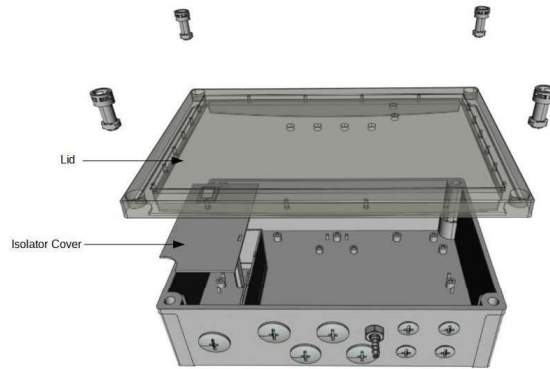

Figure 1 1002510 Lid & Cover

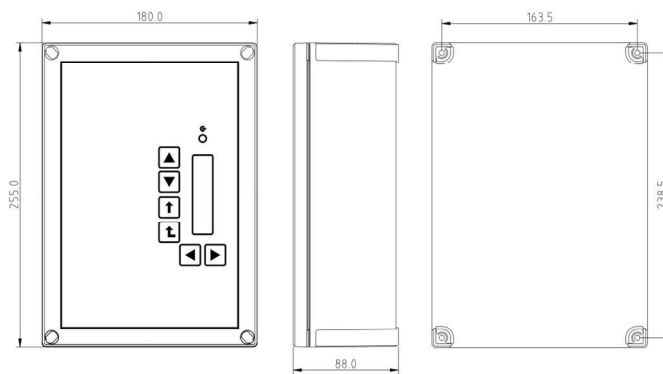

Figure 2 Enclosure & Mounting Dimensions

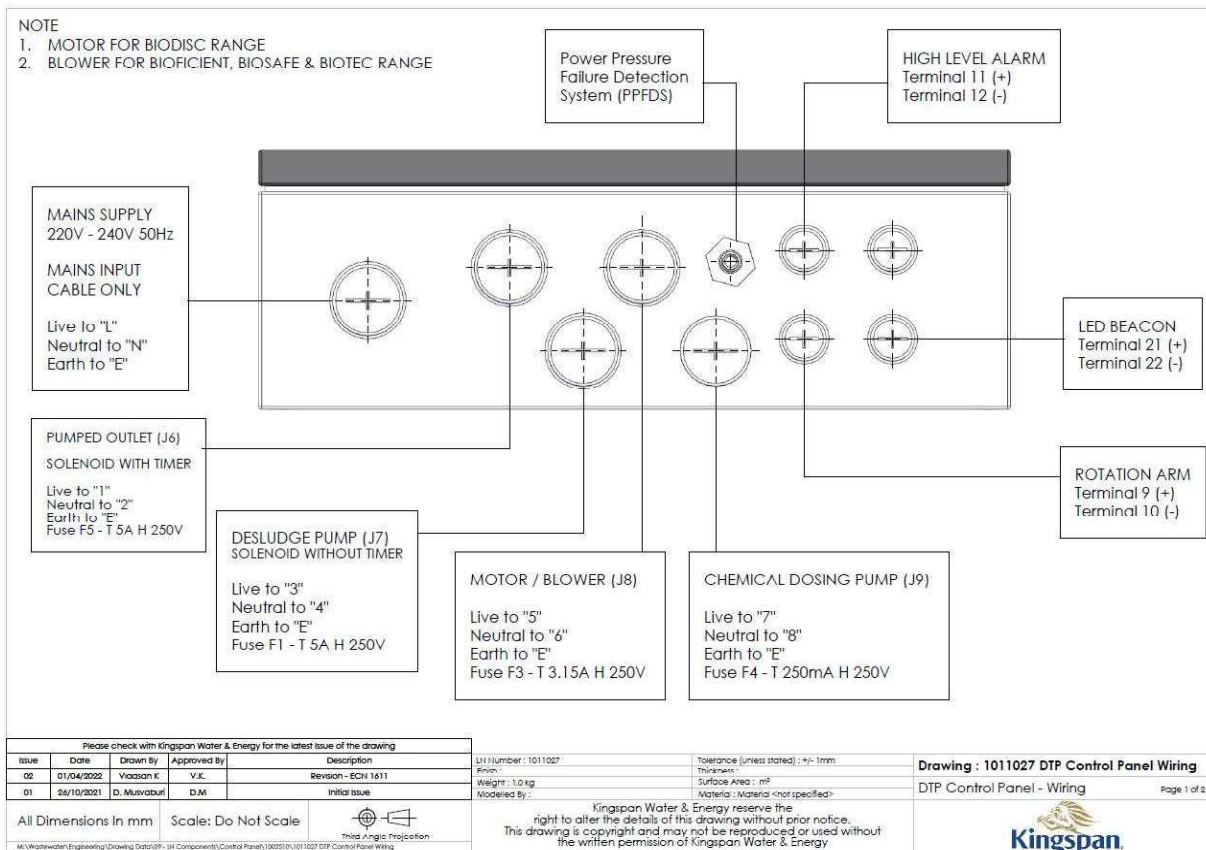

Figure 3 Control Panel Wiring (1)

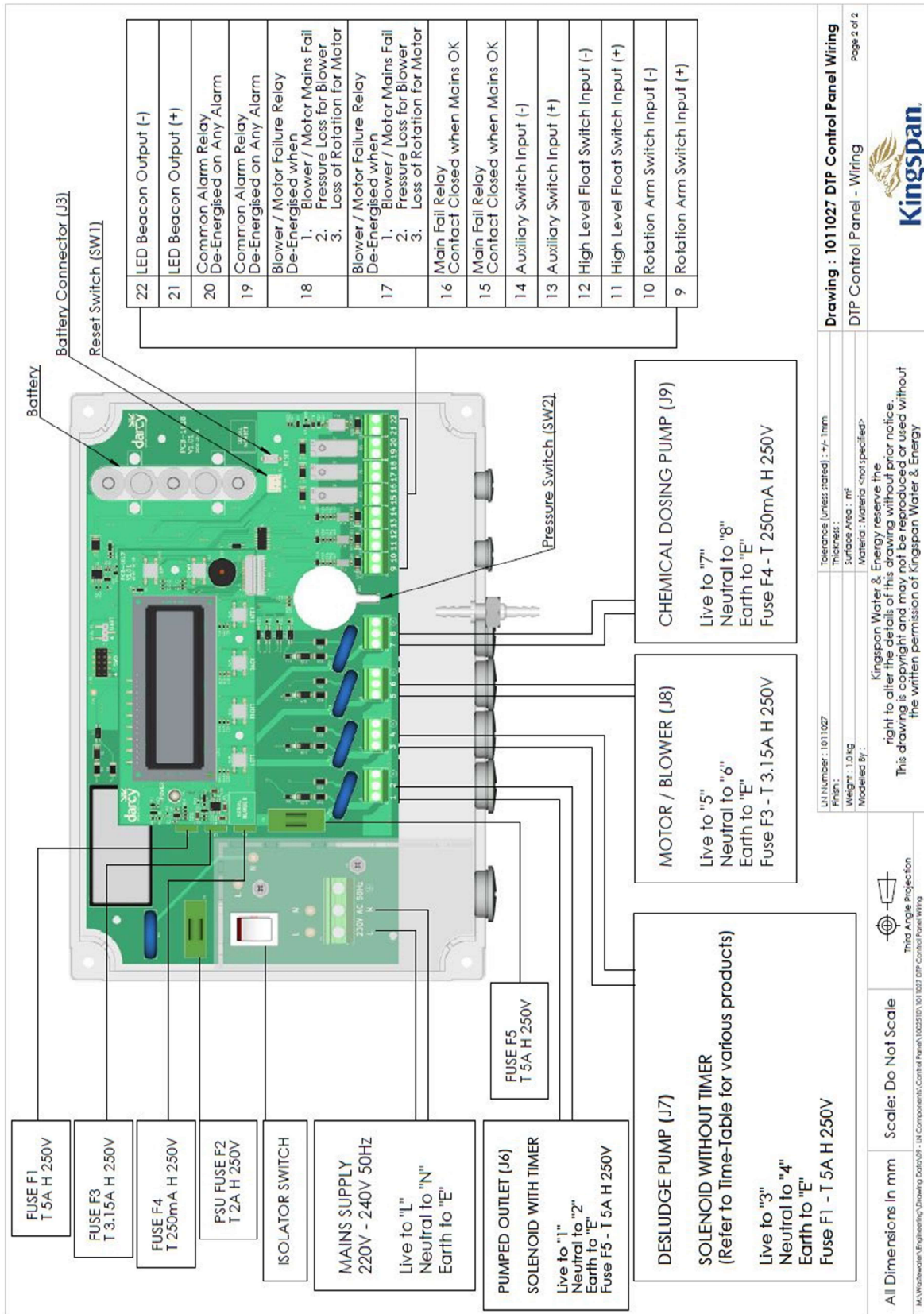

Figure 4 DTP Control Panel Wiring (2)

## 7.1. General Electrical

### 7.1.1. General Notes on Outside Electrical Installation

Only qualified and competent persons should carry out any electrical installation. Outside electrical installations can present dangers that are not usually encountered in internal electrical wiring. External equipment is subjected to the elements and attention must be made to the suitability of the cable, glands, connection units etc. for outside use. All cable glands should be IP66, or better. The possibility of attack by vermin should also be considered and adequate precautions taken.

These notes are not intended to replace the latest I.E.E. Wiring Regulations.

### 7.1.2. Electrical Supply

The electrical feed should be dedicated to the equipment and not used for any other purpose. The supply should be via a suitable RCD unit backed up by either a motor rated fuse, or preferably a motor rated MCB of suitable rating. Ensure that the blower housing is protected by a suitable RCD to BS 4293 and MCB to BS 3871. Cable installation below ground should be SWA to BS 6346, unless otherwise stipulated.

The RCD must be of the two-pole type rated at 25A/30mA. (If nuisance tripping is experienced then a sensitivity of 100mA should be used, but this does reduce the personnel protection capability).

### 7.1.3. Cable Installation

The type and size of cable depends upon site conditions and distance. If conduit/ducting is possible then providing mechanical and vermin attack protection is provided, single cables of adequate size can be used. However, the preferable method would be to use steel wire armoured (SWA) cable. This should be buried in the ground at a depth of 600mm laid on sand with warning tapes on the cable and an additional tape at a depth of 150mm.

For loads up to 0.75kW and runs of less than 100 metres, 2.5mm<sup>2</sup> 3 core SWA is adequate. For loads up to 1.55kW and runs of less than 100 metres, 4.0mm<sup>2</sup> 3 core SWA should be used. It is a requirement to use the unused core in the cable for the earth conductor and this should be sleeved with earth sleeving at both connection points.

## 7.2. General Installation

The control panel must not be adjacent to the plant. It can be mounted in the blower housing (supplied with Biotec / BioFicient / Biosafe Units), wall mounted or fixed to the mounting frame (available separately). It should be positioned so it cannot be reached by someone standing in or on the unit. It would be advisable to situate the control panel and beacon in a frequently viewed position, so if a fault alarm appears it will be seen.

### 7.2.1. Mounting Frame Installation (where applicable)

Set the frame legs in a concrete base, minimum 250mm thick and prop the frame to prevent movement until the concrete has set.

Allow 350mm minimum clearance from finished ground level to the bottom of the panel.

### 7.2.2. Retrofit of Control Panel

This Panel can replace the Kingspan Panel (P.No. 010086 - Green Panel). The existing beacon (P.No. 010332) will have to be replaced with the New Beacon (P.No. 1009254) which is provided with Control panel (P.No. 1002510) as it is not compatible with the new control panel.

## 7.3. Installation of Integral Discharge Pump (where applicable)



Using a suitable M20 gland, feed the pump power cable through Gland Hole and terminate to connections 1 & 2 (J6) according to Figure 3 & Figure 4.

## 7.4. Installation of High-Level Alarm – HLA (where applicable)



Fix the black plastic bracket to the side wall of the baffle (the exact position is on the drawing included with the HLA kit). Secure the float cable in the cable gland as shown on the drawing in the HLA kit. Pull the float cable through any installed ducting into the blower housing. Complete wiring according to Figure 3 & Figure 4.

## 7.5. Beacon units - P.No. 1009254 (where applicable)



The Beacons provides an external visual indication which is used to indicate Failure & Service Reminders and may be included in the Power and Pressure Failure Detection System (PPFDS). The beacon is provided with a 5m cable which can be extended to 30m. As supplied, the unit is protected against rain to IP65 and is supplied ready to mount on a suitable surface. Complete wiring according to Figure 3 & Figure 4.

This unit is designed to be simple to install and safe in operation. Any modification may adversely affect its weather resistance in operation. If in any doubt, please consult us for advice. This is a sealed unit and not serviceable.

## 7.6. For Biotec, Bioficient or BioSafe Applications

### 7.6.1. Power & Pressure Failure Detection System – PPFDS (where applicable)



The panel is designed to be used in conjunction with the Beacon unit to provide warning of either loss of power or air pressure failure.

For panels mounted outside the blower housing, additional tubing can be purchased, contact your local sales team for details. The panel can be mounted up to 30m away from the blower with no effect on the performance of the pressure failure detection system.

To prevent damage to the PPFDS hole is fitted with a nylon bolt and nut. If the PPFDS is to be used, replace the bolt with the air inlet bulkhead fitting supplied inside the control unit. A short length of 4mm silicone tubing and a cable tie is also supplied. Connect the tubing from the bulkhead fitting to the **Top Port** of the pressure switch, SW2, see Figure 5. Tie the cable tie on the pressure switch to prevent the tubing slipping off as it is not barbed.

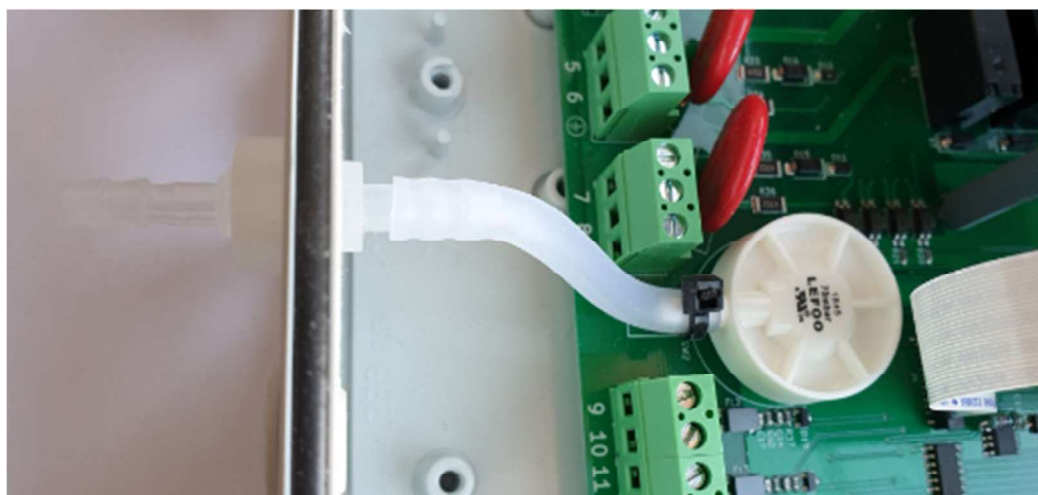

Figure 5 - Pressure switch tubing

### 7.6.2. Installation of Chemical Dosing System (where applicable)



Using a suitable M20 gland, feed the chemical dosing pump power cable through Gland Hole and terminate to connection according to Figure 3 & Figure 4. Set the run and pause times for the chemical dosing pump as described in 10.Default Timetables

## 7.7. For Biodisc Applications



Using a suitable M20 gland, feed the motor power supply cable through Gland Hole and terminate to connections according to Figure 3 & Figure 4.

### 7.7.1. Installation of Sludge Return Pump (where applicable)



Using a suitable M20 gland, feed the integral discharge pump power cable through Gland Hole and terminate to connection according to Figure 3 & Figure 4.

### 7.7.2. Installation of Chemical Dosing System (where applicable)

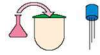

Using a suitable M20 gland, feed the chemical dosing pump power cable through Gland Hole and terminate to connection according to Figure 3 & Figure 4.

Connect the other end of the chemical dosing pump power supply cable to the junction box in the plant (marked CHEMICAL DOSING).

Set the run and pause times for the chemical dosing pump as described in 10. 10Default Timetables

### 7.8. Completing the Installation

Complete all wiring according to Figure 4 DTP Control Panel Wiring (2)

Plug the lead from the battery into the small white socket below the battery on the PCB marked J3. After finishing wiring, replace the isolator cover and screw. Turn the mains supply on at the source. Turn on the panel using the isolation switch. It should now be illuminated **RED**. The display should now show text.

Replace the top cover and screws carefully so as not to damage buttons, ensuring the lid is fixed correctly.

Follow Guide in Section 8 Configuration Programming to enable programming.

### 7.9. Ancillary Equipment

Ancillary items should be installed in accordance with the Installation Guide supplied e.g. Sewage Pump Station/Effluent Pump Station/Effluent Sample Chamber.

## 8. Configuration Programming

### 8.1. Start Up

When the control unit is powered up for the first time, the display will prompt for the country to be selected.

If any of the steps are incorrect, refer to section 8.6.7 Factory Defaults



Figure 6 Keys for Configuration

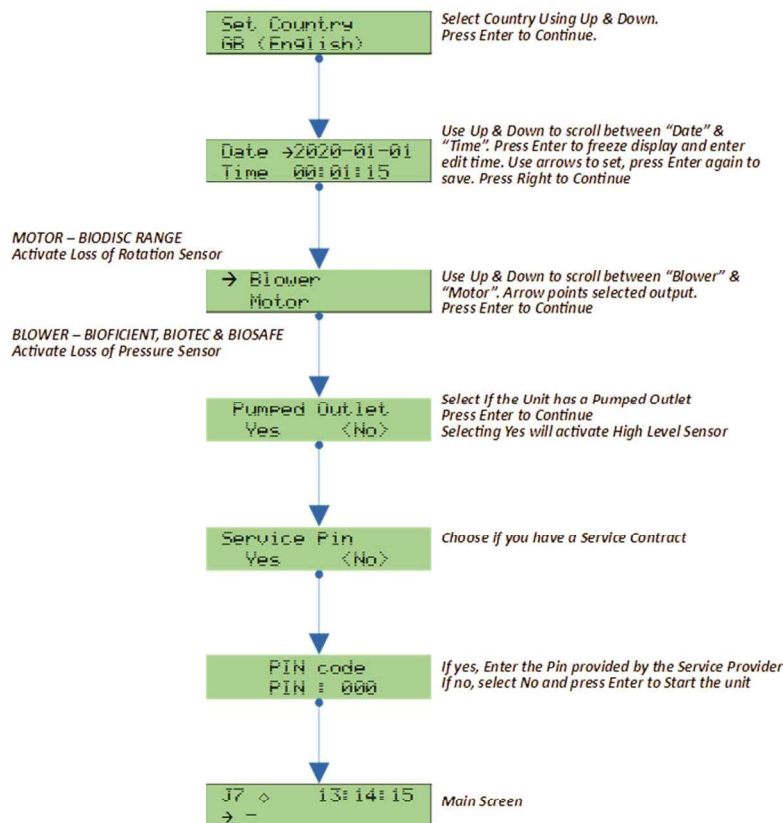

Figure 7 Initialisation



## 8.2. Detailed Operation

Once the initialisation is complete the operating screen will appear as follow. Page 1 to 6 can be navigated using ◀ & ▶ key.

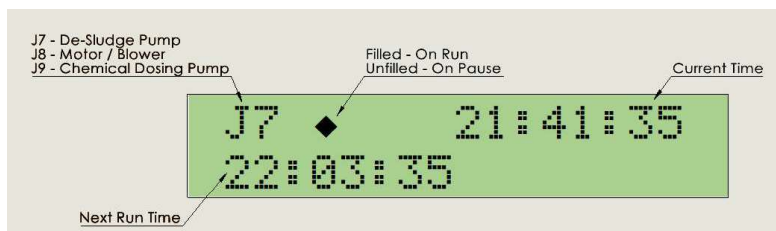

Figure 8 Main Screen Page 1

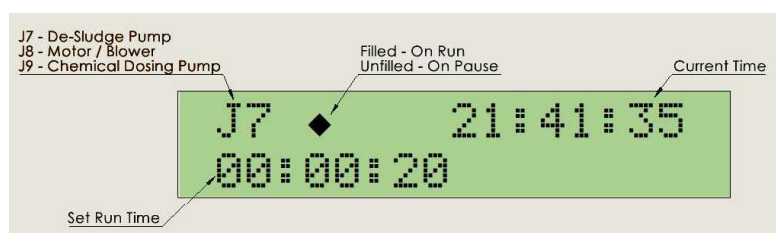

Figure 9 Main Screen Page 2

Page 3 to 6 are like the above, for Motor / Blower & Chemical Dosing Pump.

Press down key to show the date and time when the next service is due.

If only the pin is used this will show an upcoming date. If not activated, this will show a 2021 date.

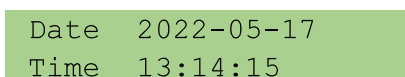

Figure 10 Next Service Due

Press down arrow to return to the initial screen showing the now activation time.

## 8.3. Alarms

The conditions shown below cause an alarm message to appear on the display, the beeper sounds, the beacon flashes, and the common alarm telemetry relay is de-energised. Some alarm conditions are recorded in the event log, along with the date and time. The display will cycle through messages if multiple alarms exist at the same time. The alarm message(s) will disappear when the alarm condition(s) have been cleared.

- Mains failure
- Low battery
- Loss of rotation
- High level float probe
- Auxiliary input
- Blower pressure
- Pumped outlet fuse
- De-sludge pump fuse
- Motor/blower fuse
- Chemical dosing pump fuse
- Service due

The beeper can be muted by pressing the '↵' button. The beeper will sound again after **SIX HOURS** if any alarm condition still exists.

## 8.4. Service

### 8.4.1. Service Due Date

The Service Due Date can be viewed on main screen by pressing '▼' until the date and time are shown.

### 8.4.2. Service Alarm

If the service alarm is activated using PIN, service alarm is reported on the display every 360 days, by default. The beacon flashes and message "Contact Service Provider" pops every few seconds.

The beacon will stop flashing by pressing the '↵' button. A service symbol appears on the screen until the next service is done & a contract renewed.

## 8.5. Telemetry Relays Outputs

There are three volt-free contacts available for alarm reporting to external systems. Follow Guide on Figure 4 for wiring.

## 8.6. Menu

Menu allows timetable entries to be edited, event log to be viewed, date/time, settings, service, battery and setting factory defaults.

This menu is intended for use by installation & Service engineers only.

The menu is entered by simultaneously pressing then releasing the three buttons '◀', '▶' & '▲'.

**On entry to the menu all outputs and telemetry relays are switched off.**

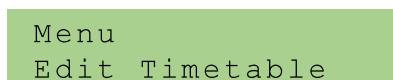

Figure 11 Menu - Edit Timetable

The current option is shown on the bottom row and is selected by '▲' and '▼'. Press the '↵' button to proceed with the current option.

**Pressing '↵' or '◀' will return to normal operation.**

### 8.6.1. Edit Timetables

Use '◀' and '▶' to select between **Start**, **Stop**, **Run**, and **Pause** times for the current timetable entry.

Use the '↵' button to edit the entry. A flashing cursor will appear over the first digit of the hour. Use '▲' and '▼' to increment and decrement the digit, respectively. Use '◀' and '▶' to move to the previous or next digit in the time, respectively. Once the entry has been edited, press the '↵' button to save changes and exit edit mode, or press the '↵' button to cancel changes and exit edit mode.

Use '↵' or '◀' to return to the menu.

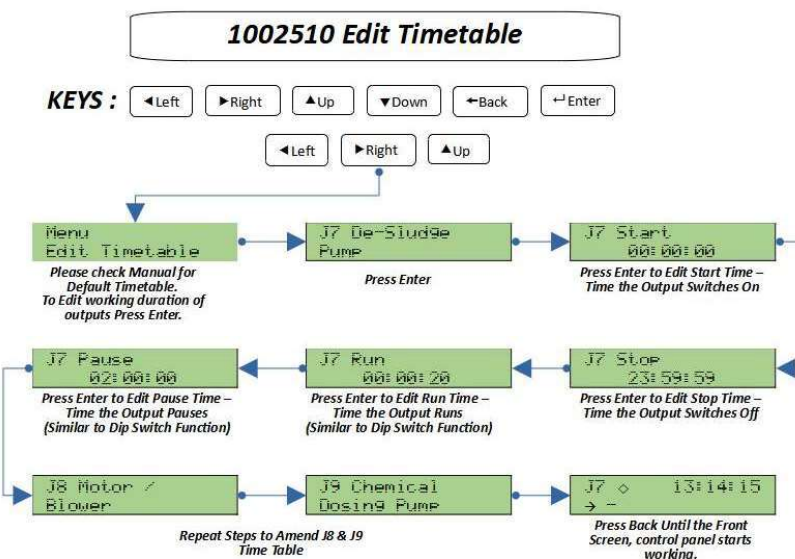

Figure 12 Editing Timetable

### 8.6.2. Event Log

This option shows the last ten alarm conditions that have occurred along with the date/time. An event is also recorded when the alarm clears. The message "Log is Empty" will appear if no alarms have been recorded yet. Use '▲' and '▼' to move through the events. Use '◀' and '▶' to alternate between the event message and the date/time the event occurred. Use '←' to return to the main menu.

### 8.6.3. Set Date & Time

This option allows the current date and time to be set in the 24-hour format. The display will show:

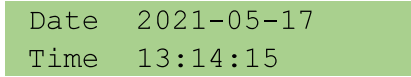

Figure 13 Date & Time

Use '▲' and '▼' to move between date and time. Pressing the '↵' button will freeze display of the clock and enter edit mode to allow the date or time to be set. A flashing cursor will appear. Use '▲' and '▼' to increment and decrement the digit, respectively. Use '◀' and '▶' to move to the previous or next digit, respectively. Once the desired date or time has been set, press the '↵' button to save changes. Use '←' to return to the main menu.

### 8.6.4. Settings

Setting can be used to amend inputs such as Loss of Rotation or Loss of Pressure, High Level Alarm & Beeper. LOR or LOP & High-Level Alarm will be enabled / disabled during the initialisation.

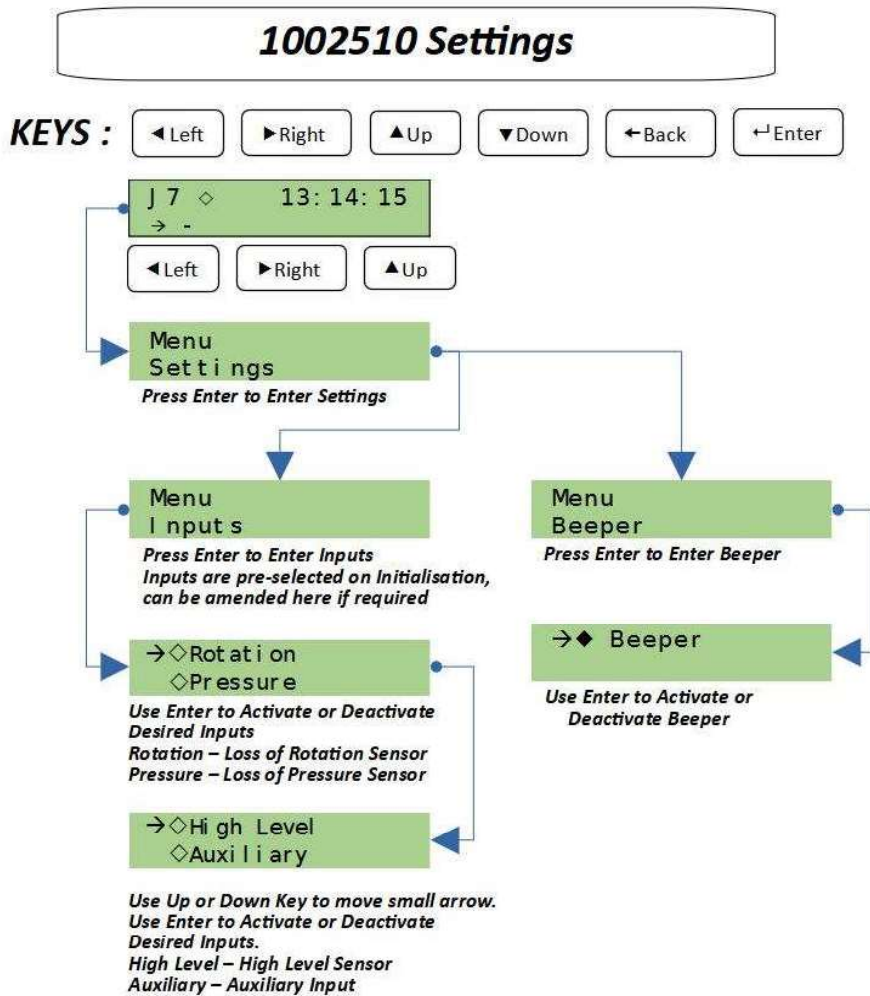

Figure 14 Settings

### 8.6.5. Service

This allows setting the interval between which service alarms occur. The default is 360 days.

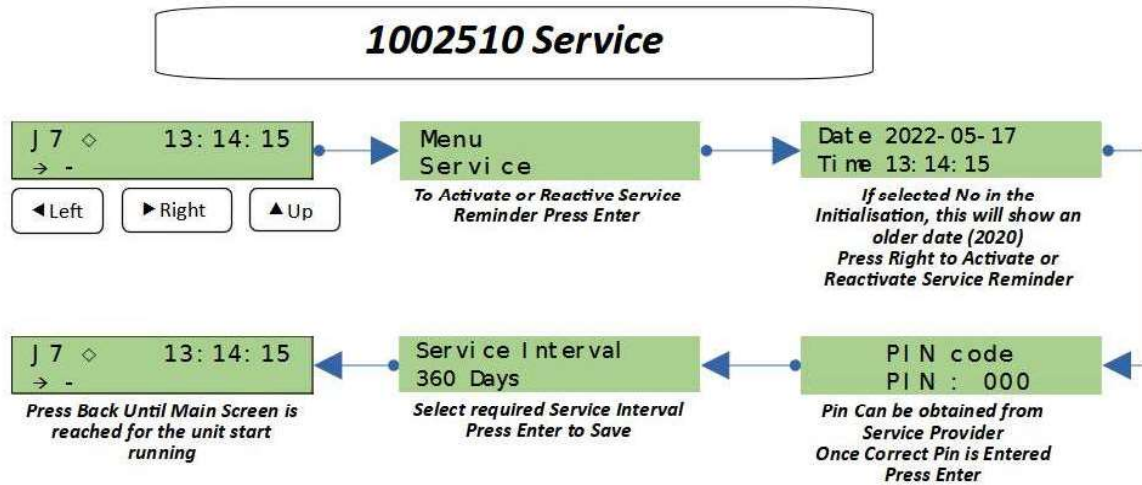

Figure 15 Service

### 8.6.6. Battery

This displays the battery charger status. The display shows “**Not Charging**” when mains power is absent. The charging countdown is paused.

“Standard charge” is displayed when the control unit first has power applied or the internal reset switch is pressed. This last for 16 hours and a countdown is shown on the display. “Intelligent Charge” is displayed when power is interrupted and shows the amount of time until the battery is fully charged. “Trickle Charge” indicates that the unit is fully charged and maintaining the battery.

### 8.6.7. Factory Defaults

This option allows the control unit to be set back to the defaults as they were when the unit left the factory. The following will be reset with defaults shown in brackets.

- Unit not activated
- Country (GB & IRE (Eng.))
- Timetables (see 10. Default Timetables)
- Event log (empty log)
- Service interval (360 days)
- Inputs (disabled)
- Blower/motor (blower)

```
Factory Defaults
Yes <No>
```

Figure 16 Factory Default

Initially the “**No**” option will be highlighted to prevent accidentally setting factory defaults if this was not intended. Use the ‘◀’ button to move to the Yes option and press the ‘↵’ button to confirm. The display will show:

```
Restarting...
```

A few seconds later the unit will restart and prompt for the country to be selected. See section 8.1 Start Up

## 9. Technical Information

### 9.1. Control Unit

Model	1002510	
Enclosure	Dimensions: 255mm (W) x 180mm (H) x 88mm (D) Ingress Protection: IP65 Material: ABS Lid Screws: Torque: 1.2Nm, Size: PH 2	
Operating Environment	Operating temperature: -20°C ... +50°C Relative humidity: 100% Altitude: 2,000m Pollution degree: 2 Intended for use indoors or outdoors, and in wet locations	
Power Source	230VAC ±10% 50Hz Mains isolator switch internal to unit	
Power Consumption (Control unit only)	6.4W, 10.1VA, $\cos \phi = 0.63$	All relays energised, battery charging, beacon off, J6 - J9 disconnected
	11.3W, 17.8VA, $\cos \phi = 0.63$	All relays energised, battery charging, beacon on continuously (not flashing), J6 - J9 disconnected
Power Consumption (Control unit and pumps/motors and beacon)	1.6kW, 1.8kVA, $\cos \phi = 0.89$ All relays energised, battery charging, beacon on continuously (not flashing)	
	J6 – Pumped outlet J7 – De-sludge pump J8 – Blower J9 – Chemical dosing pump	Grundfos KP 350 Grundfos KP 250 Secoh JDK-250, Nitto LA80B Kingspan 404390, Williamson Peristaltic Pump
Fusing	F1 (De-sludge pump, terminals 3&4)	T 5A H 250V
	F2 (Internal power supply unit)	T 2A H 250V
	F3 (Motor/blower, 5&6)	T 3.15A H 250V
	F4 (Chemical dosing pump, 7&8)	T 250mA H 250V
	F5 (Pumped outlet, 1&2)	T 5A H 250V
	F6 (Beacon output, 21&22)	500mA resettable fuse
Electrical Safety	IEC/EN 61010-1:2010+A1:2019, Class I, CAT II	
Battery Backup	6V 1200mAh NiMH battery pack kept charged by on-board charger. Backup time at least 12 hours.	
Inputs	3 x inputs from volt-free contacts (rotation arm, float switch and external alarm condition such as pressure switches in series) 1 x blower pressure sensor (alarms below 15mB, 4mm inlet)	
Mains Outputs	Relays only energised when mains power is present.	
	Pumped outlet (1&2)	Constant mains output, fused T 5A H 250V
	De-sludge pump (3&4)	SPST relay switched, fused T 5A H 250V
	Motor/blower (5&6)	SPST relay switched, fused T 3.15A H 250V
	Chemical dosing pump (7&8)	SPST relay switched, fused T 250mA H 250V
Telemetry Relay Outputs	3 x volt-free SPST contacts. De-energised in alarm condition. <b>Use only with 30V, 3A AC/DC max.</b> <b>Unfused</b>	

	Relays only energised when mains power is present.	
	Terminals 15&16	Mains failure
	Terminals 17&18	Motor or blower failure
	Terminals 19&20	Common alarm
Beacon Output	Output suited for use with 1009254 LED beacon. Flashes continuously on alarm when mains present, 12 hours in battery backup mode.	
Mains Outputs Voltage Sensing	Pumped outlet, de-sludge pump, motor/blower, chemical dosing pump. The voltage is monitored on these outputs to determine if a fuse has blown. An alarm is raised in such a condition.	
PPFDS Input	4mm barbed air inlet for pressure sensing. Alarm below 15mB.	
Audible Alarm	Internal sounder sounds in bursts at intervals on alarm. Can be muted for 6 hours by pressing enter key on front panel. Can be disabled from on-screen menu.	
Keypad	Left, right, up, down, back and enter.	
Display	16 x 2 character LCD Green power LED	
Real-Time Clock	Event log timestamps and controlling the operation of the motors/blowers according to a timetable	

## 9.2. LED Beacon 1009254

Only the LED beacon 1009254 should be used with the 1002510 control unit as it has been specifically designed for this product. Although a 12V beacon could be used when the control unit has mains power available, in battery backup mode the voltage available is only nominally 6V and the 12V beacon would probably fail to operate and 6V beacons are not commonly available. For these reasons and to keep the beacon brightness constant on mains power and battery backup, the 1009254 has internal constant current circuitry to maintain a constant 400mA consumption.

Model	1009254
Enclosure	73mm (Diameter) 48mm (Height) 11.5mm (Base mounting plate height) Ingress Protection: IP65 Material: ABS
Operating Temperature	-20°C ... +50°C
Operating Voltage	6 – 12V
Current Consumption	400mA constant current
Static/Flash	Flash rate and duration controlled by firmware in 1002510 control unit
Lens Colour	Red
Cable Length	5m

## 10. Default Timetables

### 10.1. De-sludge Pump

#### 10.1.1. UK, Germany, France & Poland

Function	Default	Bioficient	BioFicient + 1	BioFicient + 2
Start Time	00:00:00	00:00:00	00:00:00	00:00:00
Stop Time	23:59:59	23:59:59	23:59:59	23:59:59
Run Time	00:00:20	00:05:00	00:01:00	00:01:30
Pause Time	02:00:00	01:00:00	01:00:00	01:00:00

Table 1 De-Sludge Default (GB & IRE, DE, FR, PL)

Function	Biosafe/Delta 1	Biosafe/Delta 3	Biosafe/Delta 4
Start Time	00:00:00	00:00:00	00:00:00
Stop Time	23:59:59	23:59:59	23:59:59
Run Time	00:05:00	00:00:30	00:00:20
Pause Time	01:00:00	01:59:30	00:59:40

Table 2 De-Sludge Default (GB & IRE, DE, FR, PL) Continuation

#### 10.1.2. Norway

Function	Default (BioDisc)	Biosafe 1 (Norway)
Start Time	00:00:00	00:00:00
Stop Time	23:59:59	23:59:59
Run Time	00:00:20 (20 Sec)	00:02:00 (2 mins)
Pause Time	02:00:00 (2 hours)	00:58:00 (58 mins)

Table 3 De-Sludge Default (Norway)

### 10.2. Motor/Blower

Start Time (Time of Day where Unit is started)	:	00:00:00
Stop Time (Time of Day where Unit is stopped)	:	23:59:59
Run Time (Time for the components to Run)	:	23:59:59 (24 hours)
Pause Time (Time for the components to Stop)	:	00:00:00 (0 minutes)

Table 4 Motor / Blower Default

### 10.3. Chemical Dosing Pump

#### 10.3.1. UK, Germany, France & Poland

Start Time (Time of Day where Unit is started)	:	00:00:00
Stop Time (Time of Day where Unit is stopped)	:	23:59:59
Run Time (Time for the components to Run)	:	00:00:03 (3 Sec)
Pause Time (Time for the components to Stop)	:	00:25:00 (25 minutes)

Table 5 Chemical Dosing Default (GB, DE, FR, PL)

#### 10.3.2. Norway

Function	Default	BA	BB	BC	BD	Biosafe 1 (Norway)
Start Time	06:00:00	06:00:00	06:00:00	06:00:00	06:00:00	06:00:00
Stop Time	22:00:00	23:59:59	23:59:59	23:59:59	23:59:59	23:59:59
Run Time	00:00:02	00:00:03	00:00:03	00:00:03	00:00:03	00:00:04
Pause Time	01:00:00	00:48:00	00:24:00	00:16:00	00:12:00	00:59:56

Table 6 Chemical Dosing Default (Norway)

---

# Contact Details

---

**Kingspan Water & Energy Ltd.**  
College Road North  
Aston Clinton | Aylesbury  
Buckinghamshire | HP22 5EW

T: +44 (0) 1296 633 000  
F: +44 (0) 1296 633 001  
E: [klargester@kingspan.com](mailto:klargester@kingspan.com)

[www.kingspan.co.uk/klargester](http://www.kingspan.co.uk/klargester)

We take every care to ensure the information in this document is accurate at the point of publication.  
©Kingspan and the Lion Device are Registered Trademarks of the Kingspan Group in the UK, Ireland and other countries. All rights reserved. Registered in Country No. NI017631. Registered Office: 180 Gilford Road, Portadown, Co. Armagh, BT635LF. VAT GB412 5124 03

Mktg. Comp. Code (Covers only)
04/2022_5653

