

Pumpstation CK 800 – Packaged Single-pump or Dual-pump Station

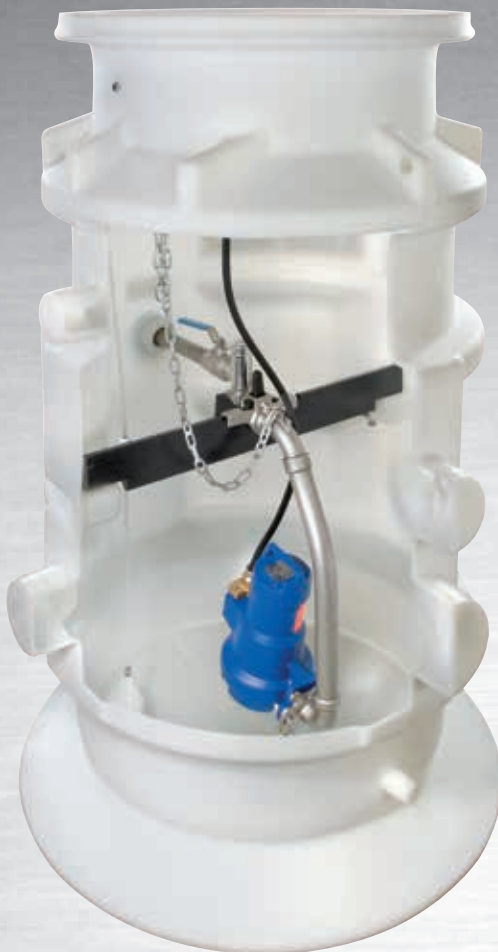

Applications:

- Waste water disposal from buildings and premises below flood level
- Redevelopment of premises
- Disposal of waste water in private, commercial, industrial, and municipal sectors
- Joint sewage disposal for several houses or apartments (e.g. terraced houses)
- Pumped drainage
- Also retrofittable to solve drainage and back-flow problems in older housing areas

More information:

www.ksb.com/products

Pumpstation CK 800 – Packaged Single-pump or Dual-pump Station

Top quality and optimum value for money

1 Flexible

Free choice of installation position

- Tank cover available for load classes A, B and D
- Tank extensions for installation depths of up to 2.750 mm

2 Anti-lift protection as a standard

Up to a maximum installation depth of 2.70 m – statically tested by independent experts.

3 Cost-optimised

Light-weight ready-to-connect tank makes for minimum transport and installation costs.

4 Easy to install

- Pump easy to install and remove thanks to above-water coupling and an attachment device allowing the pump to settle at its centre of gravity
- Large variety of connection options with 4 inlet nozzles at different levels and directions

5 Durable

High-quality, corrosion-resistant installation components.

6 Maintenance-friendly

Valves can be operated easily without the need to access the tank.

7 Reliable

- Optimum tank design reduces accumulation of deposits
- Inclined pump position minimises the formation of floating sludge

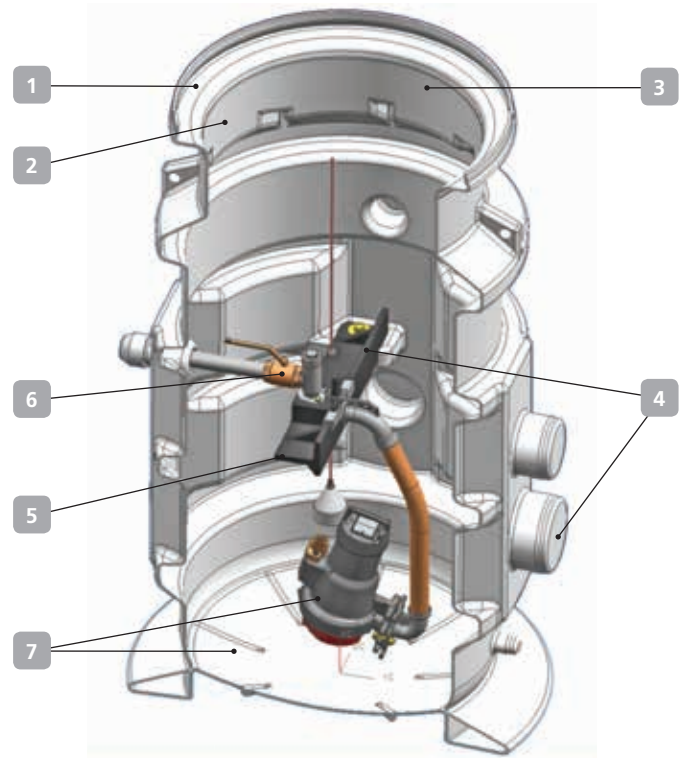

Simplified planning

Uniform tank for all cutter pumps of the Amarex® N and Ama-Porter® type series.

Fluid handled

- Domestic sewage (containing faeces, solids or fibre)
- Waste water, Storm water
- Please note: For pumping faeces the explosion protection regulations must be heeded

Materials

Tank	Polyethylene
Cross beam with coupling component	Polyethylene
Discharge pipe with coupling	Stainless steel
Angle globe valve	Stainless steel
Ball valve	Stainless steel
Discharge line	Stainless steel

Technical Data

	Ama-Porter® S	Amarex® N S
Flow rate Q	Up to 17 m³/h	Up to 22 m³/h
Discharge head H	Up to 21 m	Up to 49 m
Motor rating	Up to 1.5 kW	Up to 4.2 kW
Temperature t	Up to 40 °C	Up to 40 °C
Cable length	10 m	10 m

Automation option: LevelControl Basic 2



KSB Aktiengesellschaft
Johann-Klein-Straße 9
67227 Frankenthal (Germany)
www.ksb.com