

one2clean / one2clean plus installation instructions

one2clean

Item no.

106850 Set-up kit 3 inhabitants
106851 Set-up kit 5 inhabitants
106852 Set-up kit 7 inhabitants
106853 Set-up kit 9 inhabitants

one2clean plus

Item no.

106417 / 106413 Set-up kit 3 inhabitants
106418 / 106414 Set-up kit 5 inhabitants
106419 / 106415 Set-up kit 7 inhabitants
106420 / 106416 Set-up kit 9 inhabitants

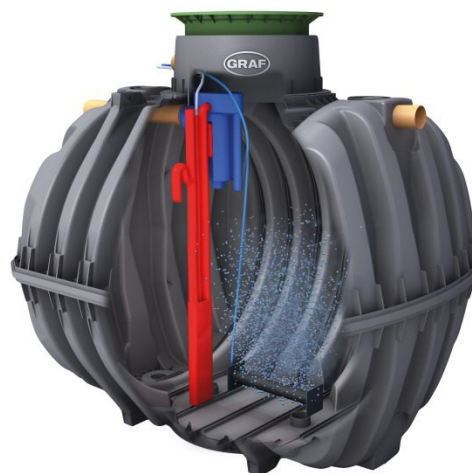

It is essential that you observe the points described in these instructions. Failure to do so will invalidate all warranty claims. For all additional items ordered from GRAF, separate installation instructions will be provided in the transport packaging.

It is essential that you check the components for possible damage before installation.







You will receive separate instructions for assembling the system.

Contents

1.	SCOPE OF DELIVERY	13
2.	NOTES	14
2.1	Safety	14
2.2	Ventilation and bleeding	14
3.	CONSTRUCTION AND FUNCTIONAL PRINCIPLE	15
4.	ASSEMBLING THE SET-UP KIT	16
5.	ASSEMBLING CONTROL UNIT IN THE INTERIOR	20
6.	ASSEMBLING CONTROL UNIT IN THE EXTERNAL CABINET	21
7.	TECHNICAL DATA	22

1. Scope of delivery

1. Scope of delivery

		
Jack	Sampler	1 pipe aerator for 3 and 5 inhabitants 2 pipe aerators for 7 and 9 inhabitants
		
Scum board	Control (one2clean plus control without illustration)	Accessories

The following is not included in the scope of delivery:

- Hoses to supply air from the control cabinet to the septic tanks. One 13 mm air hose and one 19 mm air hose are required.

They can be ordered under the following item numbers:

Hose package, 10 metres	107686
Hose package, 20 metres	107688

The hose packages each contain one 13 mm air hose and one 19 mm air hose. Alternatively, the hoses can be ordered as rolled goods:

PVC hose, 20 metres, black, 13 x 3 mm	934017
PVC hose, 20 meters, blue, 19 x 3 mm	934020

- Core drill with a diameter of 124 mm. This can be purchased from Otto Graf GmbH using item number 202003.
- The Carat S septic tank and covers are to be ordered separately.

2. Notes

2. Notes

2.1 Safety

Observe the national accident prevention regulations during all work. Particularly for inspecting the tanks, a second person is required for safety reasons.

Furthermore, observe the valid national regulations and standards during installation, assembly, maintenance and repair work, etc.

During all work on the system or parts thereof, always shut down the entire system and secure it against unauthorised re-start.

Always keep the tank cover closed, except when working in the tank. Otherwise, there is a high risk of an accident occurring. Only genuine GRAF covers or covers that GRAF has approved in writing must be used.

GRAF offers an extensive range of accessories, which are all coordinated to one another and can be expanded to form complete systems. The use of accessories that have not been approved by GRAF results in the exclusion of the warranty/guarantee.

2.2 Ventilation and bleeding

All tanks must be ventilated and bled. Additional ventilation lines or ventilation openings must be ordered if necessary. Ventilation lines should be ordered to guarantee natural ventilation (chimney effect).

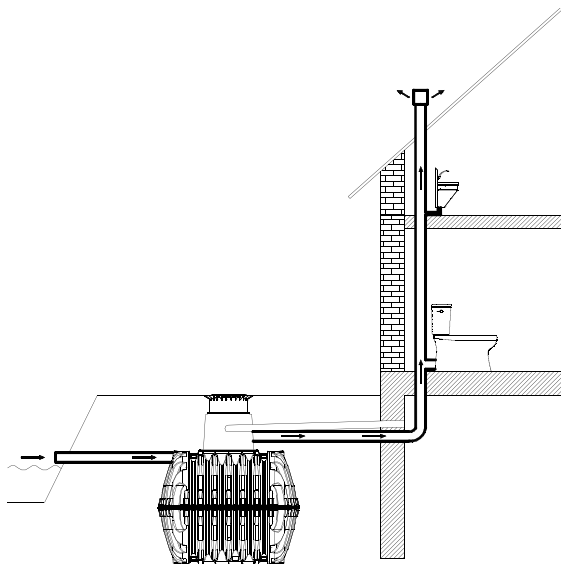

Bleeding with a free outflow

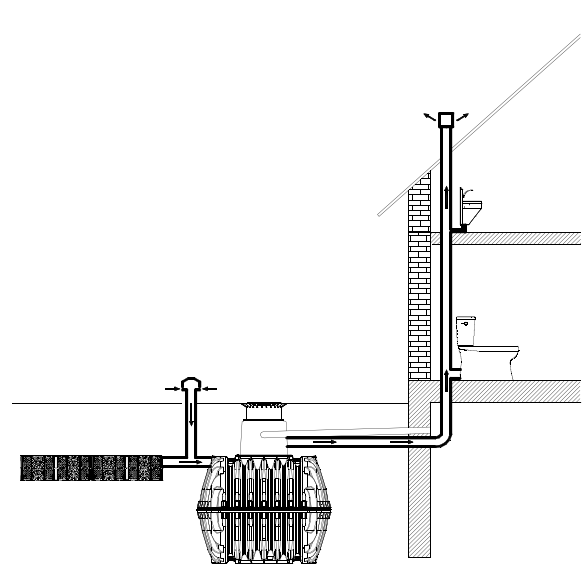

Bleeding with percolation or an obstructed outflow

3. Construction and functional principle

3. Construction and functional principle

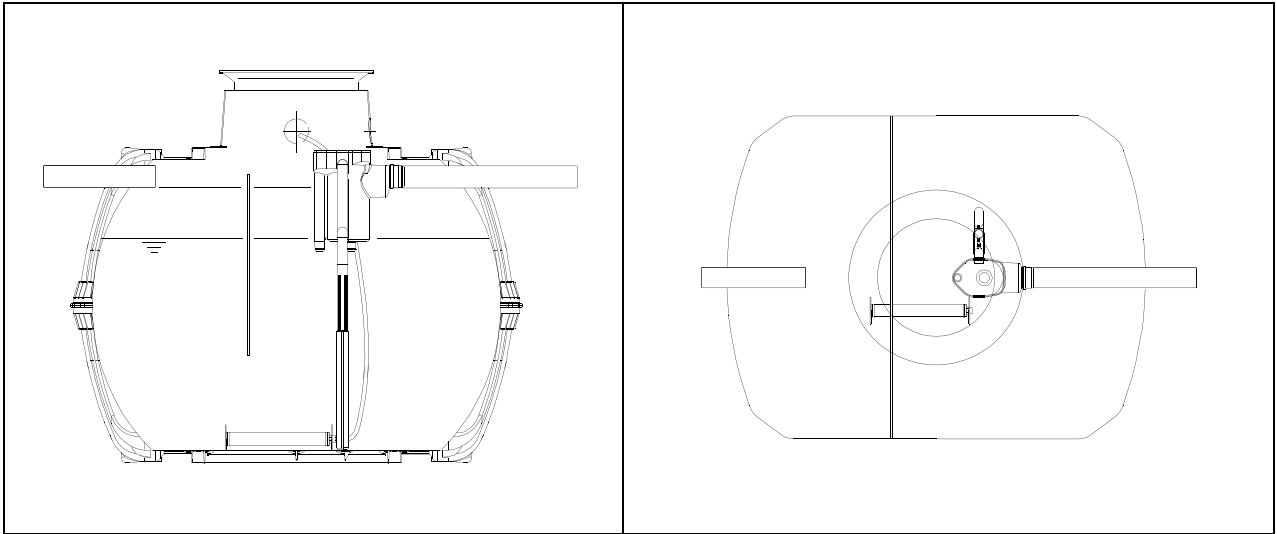

The small wastewater treatment system is fully biological and works according to the retention process with long-term aeration. The system is made up of an aerobic stage. A scum board is used to split this stage into a coarse substance chamber and an activation chamber. The chambers are connected to one another in the bottom section. During this process, therefore, all domestic sewage is immediately exposed to aerobic wastewater treatment. The entire system is aerated due to compressed air being blown in and the sludge activated as a result of this biologically cleans the wastewater.

4. Assembling the set-up kit

4. Assembling the set-up kit

1.



Unfold the scum board. Place the clamps on either side of the folding edges.

2.



Insert the scum board into the upper shell. A groove offsets in an off-centre position.

3.



The fixing clamp has to be pushed with the rounded stick in to the baffles side. The fixing clamp has to be fixed.

4.



Once the baffle has been positioned perforate the inner rib directly above the wall using an 8mm. drill head.
Perforate the baffle 4 cm. from its edge using the same 8 mm. drill head.

5.



Pass a cable tie through both holes and tighten it. Cut the excess cable tie.

Repeat this procedure on the opposite side

6.



Continue assembling the Carat RS tank according to the installation instructions (seal, centring pins, lubricant).

4. Assembling the set-up kit

7.



Place the upper shell with the scum wall on top of the lower shell. Assemble the clamps for connecting the upper and lower shells.

8.



Assemble the clamps for connecting the upper and lower shells.

9.

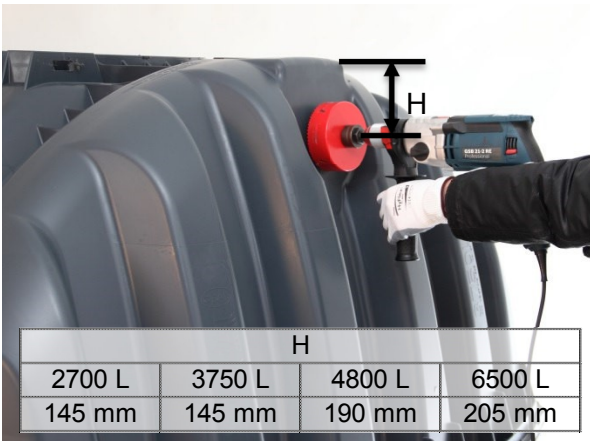

Drill the inflow and outflow with a DN 100 core drill (with a diameter of 124 mm).

10.



De-burr the hole. Insert the DN 100 lip seal. In the case of the outflow, the direction of the feed-through must be from the inside out. Affix the "Out-flow" sticker.

11.



Slide the outflow pipe through the outflow hole from the inside.

12.



The jack base must be turned depending on the tank size. The specified tank size on the base must be the same as on the jack.

4. Assembling the set-up kit

13.

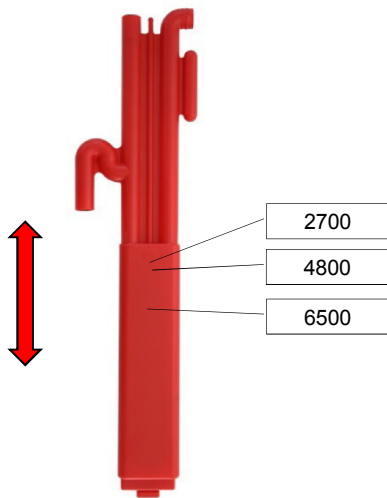

Depending on the tank size, the length of the jack must be adjusted by moving the jack base. The rough position is specified on the jack. The exact height is to be determined inside the tank.

14.



Assemble the jack and sampler. To do this, push the jack outflow into the sampler hole.

15.



Push the jack into the sampler (until it snaps into place).

16.



Insert the jack into the tank along with the sampler.

17.



Insert the jack into the profile for holding the partition wall from above.

18.



Insert the sampler's outflow connection into the sleeve of the outflow pipe (use lubricant!). The sleeve connection must be secured with a Spax screw.

4. Assembling the set-up kit

19.

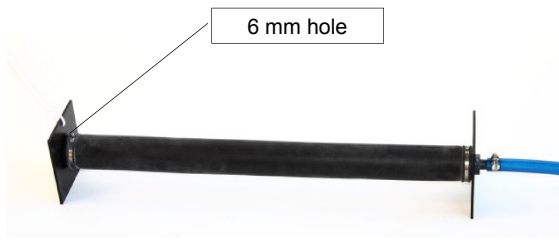

The cord must be secured to the pipe aerator (6 mm hole). The air hose (19 mm) must be connected on the opposite side. Systems for more than 7 inhabitants have two pipe aerators.

20.

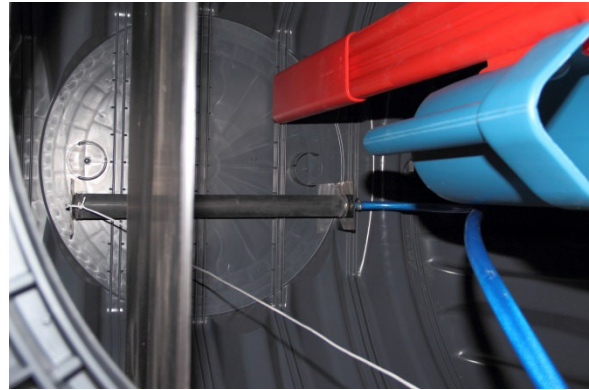

Position the pipe aerator(s) on the bottom of the tank. It must be slid under the scum board such that even the first chamber is ventilated. To attach the cord, a hook is fitted inside the tank dome. The hole for the hook should be pre-drilled with a 4mm bit.

21.



In systems with two pipe aerators, use a Y-piece to join the hoses of the two pipe aerators.

22.



Assemble the tank dome according to the installation instructions (seal!).

23.



Secure the sampling tank to the tank dome with a Spax screw.

24.



Connect the air hose (13 mm) to the in-feed jack.

5. Assembling control unit one2clean in the interior

5. Assembling control unit one2clean in the interior

1.



The control must be installed in a dry and dust-free interior. Two 8 mm holes must be drilled into the wall for assembly.

2.



Secure the control to the wall using the dowels and screws provided.

3.



Position the compressor on the control. Connect the compressor to the control unit pipe using the 90 Deg hose piece and hose clamps provided. Plug the compressor plug into the control socket.

4.



Connect the air hoses to the control's hose nozzles.

5.

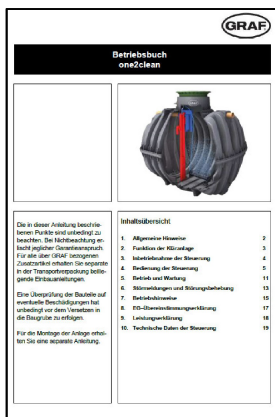





For further information please refer to the Control Unit operating manual.

Note for one2clean plus control: Assembly of one2clean plus control similar to one2clean control.

6. Assembling control unit in the external cabinet

6. Assembling control unit in the external cabinet

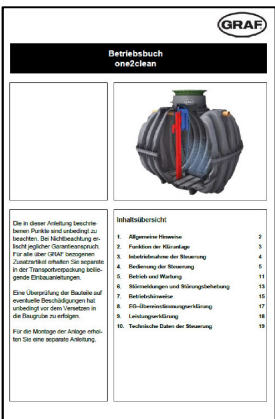
1.	 <p>Please refer to the installation instructions for the External Cabinet for electrical connection details.</p>	 <p>Before installing the control unit, a strip of foam rubber must be glued to the back of the control unit.</p>	2.
3.	 <p>The Control Unit should be mounted to the external cabinet with the screws and wing nuts provided.</p>	 <p>Position the compressor on top of the Control Unit and connect together using the 90 Deg hose piece and hose clamps provided.</p>	4.
5.	 <p>For further information please refer to the Control Unit operating manual.</p>		

7. Technical data

7. Technical data

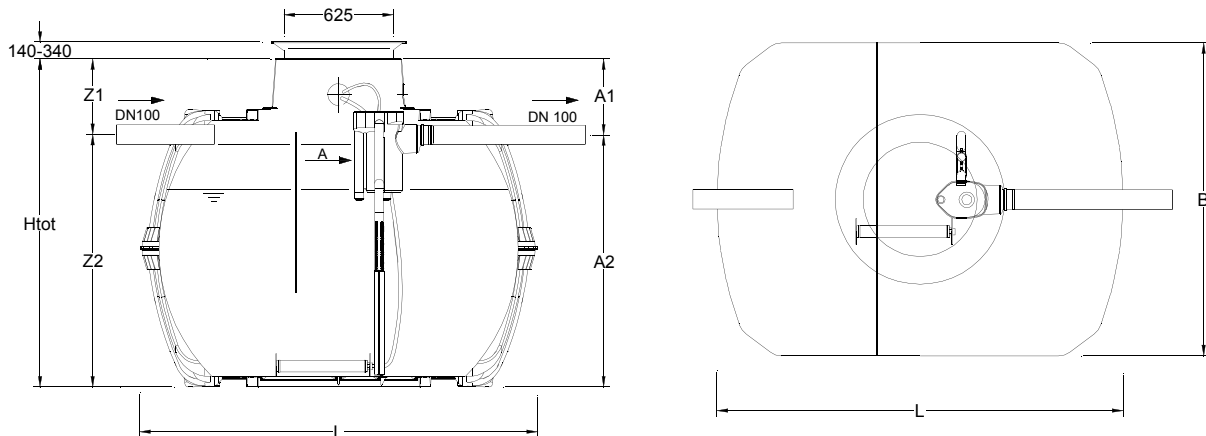

Tanks	2,700 l	3,750 l	4,800 l	6,500 l
Inhabitants	1-3 inhabitants	4-5 inhabitants	6-7 inhabitants	8-9 inhabitants
Max. daily inflow	0,45 m ³ /d	0,75 m ³ /d	1,05 m ³ /d	1,35 m ³ /d
Length L	2,080 mm	2,280 mm	2,280 mm	2,390 mm
Width B	1,565 mm	1,755 mm	1,985 mm	2,190 mm
Height H _{tot}	1,690 / 2,010* mm	1,870 / 2,200* mm	2,100 / 2,430* mm	2,380 / 2,710* mm
Inflow Z1	430 / 750* mm	430 / 750* mm	515 / 835* mm	535 / 855* mm
Inflow Z2	1260 mm	1450 mm	1595 mm	1855 mm
Outflow A1	470 / 800* mm	470 / 800* mm	470 / 800* mm	470 / 800* mm
Outflow A2	1255 mm	1445 mm	1590 mm	1850 mm

* with Maxi tank dome