

Ø1260 mm

Ø465 mm

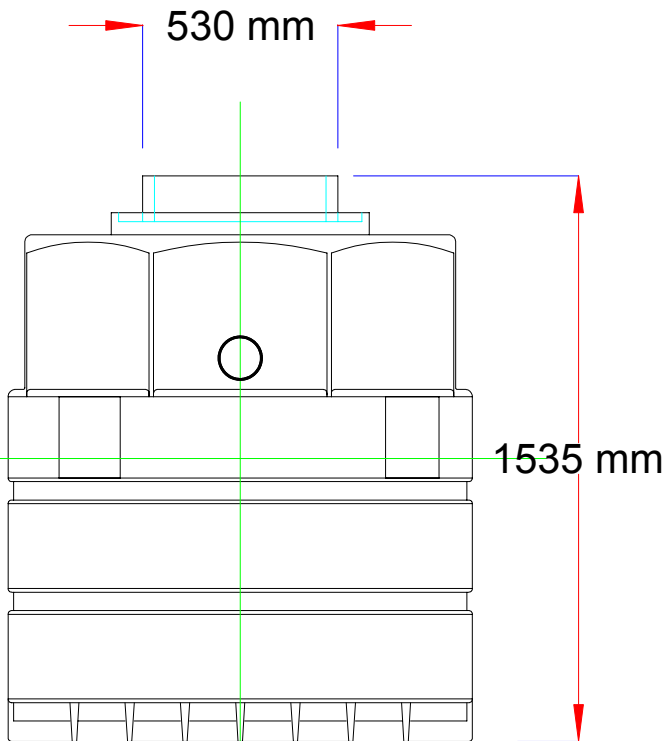
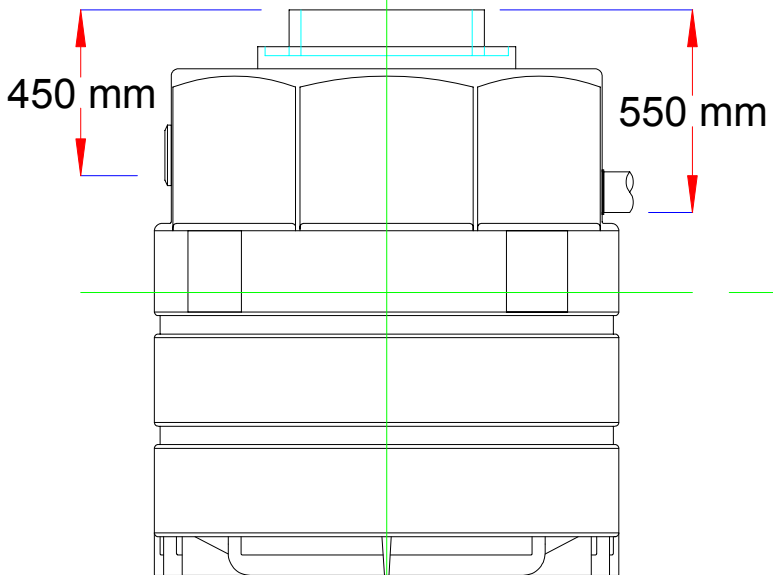

NOTES:

REV	DETAIL	DATE	DRAWN
5	Adapted to OE1214 sump	17/07/13	gf
4	Image & specification added	07/08/12	gf
3	Ribbed base added	16/12/10	gf
2	Dip pipe added	01/04/10	gf
1	Grease filter amended	10/01/08	gf

© Oaklands Environmental Ltd 2013. We reserve the right to change specification without prior notification in line with our policy of continuous development.



Oaklands Environmental Ltd
 18 Harvey Close, Crowther Ind Est
 WASHINGTON, Tyne & Wear
 United Kingdom, NE38 0AB
 Tel: 00 44 (0)191 532 2030
 Fax: 00 44 (0)191 565 2946
 sales@oaklandsenvironmental.com
 www.oaklandsenvironmental.com
 Part of the Oaklands Group of Companies

TITLE GS1 General arrangement		DWG NO GA1100/07
CUSTOMER	DATE 04/09/2007	REV 5
THIRD ANGLE PROJECTION	DRAWN gf	SCALE Not to scale
	TOLERANCE +/- 2%	SHEET 1 of 1