

© Oaklands Environmental Ltd 2011. We reserve the right to change specification without prior notice in line with our policy of continuous development.

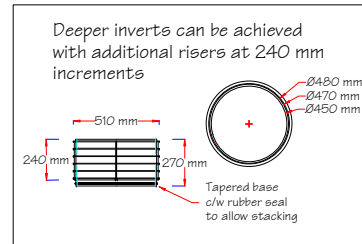

Notes:

Aproximate covers/day	2750
Nominal working capacity (litres)	3000
Sludge capacity (litres)	1800
Standard pipe connections	Ø110mm

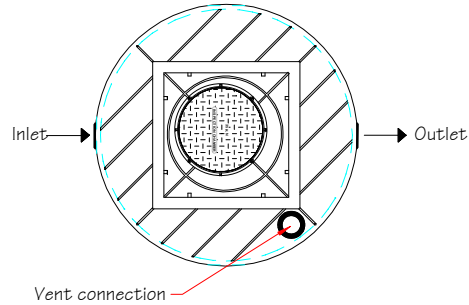
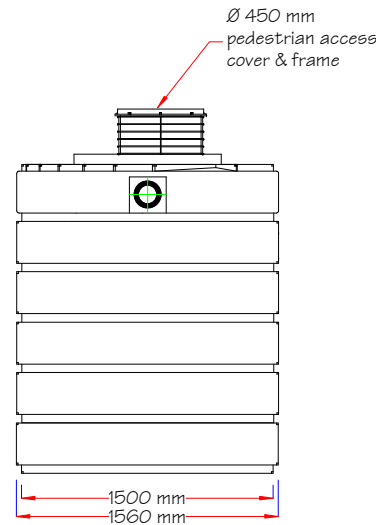
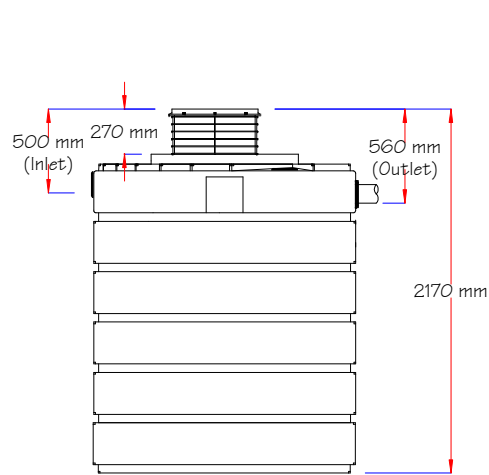

Oaklands Environmental Ltd
Unit 5b Eastway
Rivergreen Industrial Estate
SUNDERLAND
Tyne & Wear SR4 6AD
Tel: 00 44 (0)191 415 9090
Fax: 00 44 (0)191 565 2946
www.oaklandsenvironmental.com
PART OF THE OAKLANDS GROUP OF COMPANIES

REV	DETAIL	DATE	DRAWN

TITLE	GS3 Grease separator General arrangement drawing
CUSTOMER	

DRAWING NO	GA2085/11	DATE	17/02/2011	DRAWN	af
THIRD ANGLE PROJECTION				SCALE	NOT TO SCALE
				SHEET	1 of 1
TOLERANCE +/- 2%				REV	0