

Notes:

- Unit supplied c/w Ø450mm pedestrian cover and frame
- Inlet - Ø110 pipe seal
- Outlet - Ø110 socket
- 300 litre nominal capacity
- 180 litre sludge capacity
- Weight - 17.5 kg

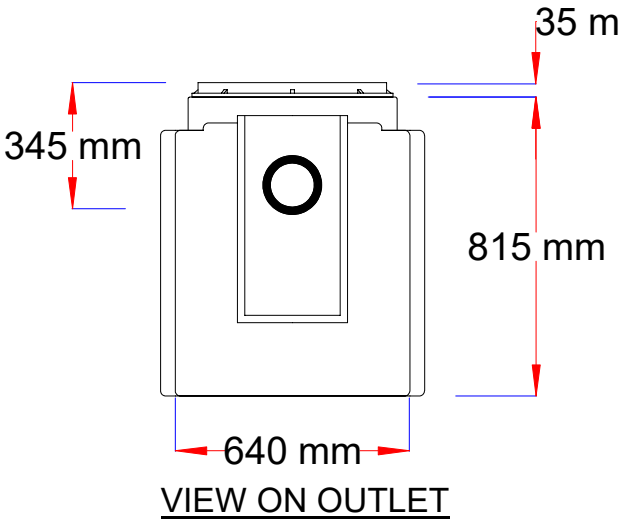
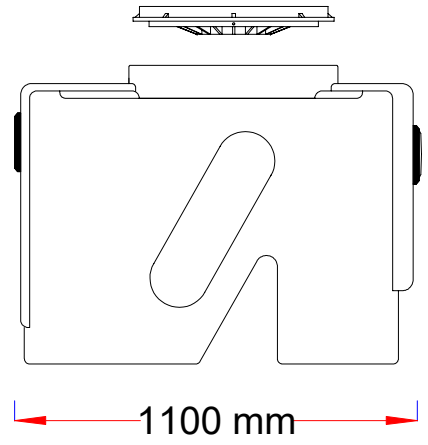
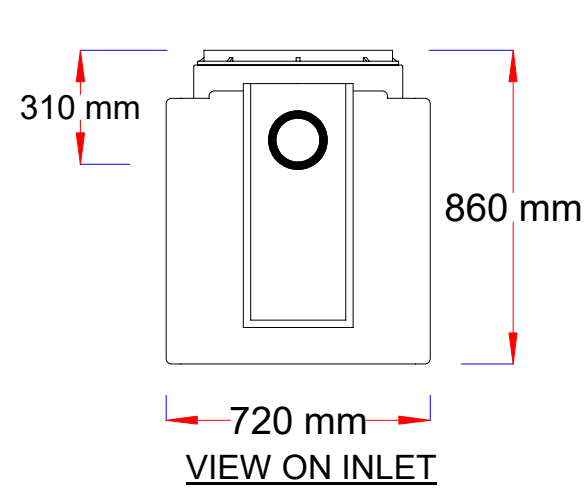

Oaklands Environmental Ltd
 MOULDING A SUSTAINABLE FUTURE

© Oaklands Environmental Ltd 2017.
 We reserve the right to change specification without prior notice in line with our policy of continuous development.

www.oaklandsenvironmental.com

PART OF THE OAKLANDS GROUP OF COMPANIES

REV	DETAIL	DATE	DRAWN
1	Amended to illustrate optional riser	04/04/12	gf
2	Rebranded as Jumbo Midi®	30/08/17	gf

TITLE	Jumbo Midi® General Arrangement	
CUSTOMER		

DRAWING NO	GA2036/10	DATE	24/05/2010	DRAWN	gf
THIRD ANGLE PROJECTION			SCALE		
			NOT TO SCALE		
TOLERANCE +/- 2%			SHEET		
			1 of 1		
REV					2