

- Notes:
- Unit supplied c/w Ø450mm pedestrian cover and frame
 - Inlet - Ø110 pipe seal
 - Outlet - Ø110 socket
 - 600 litre nominal capacity
 - 500 litre sludge capacity
 - Weight - 35 kg

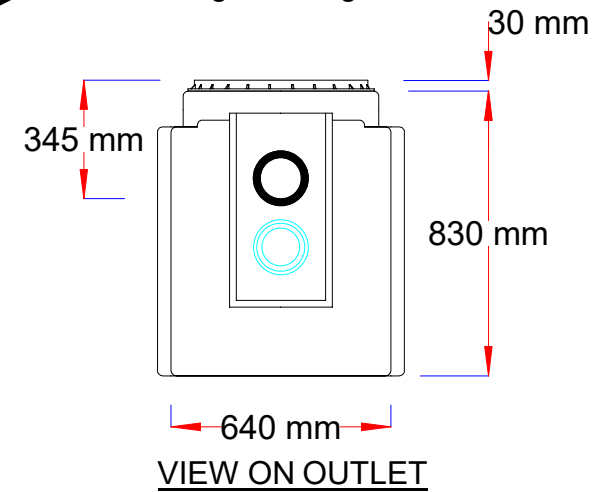
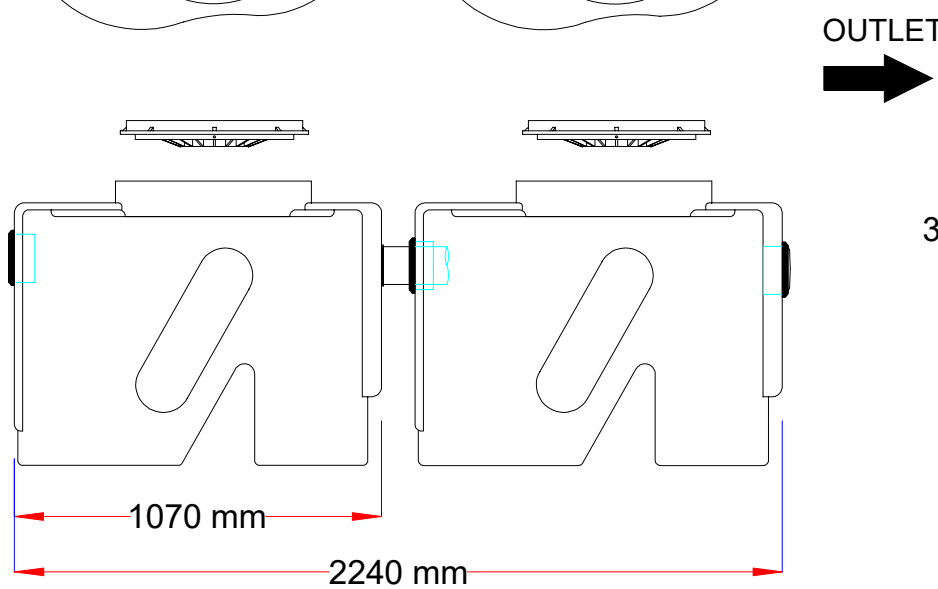
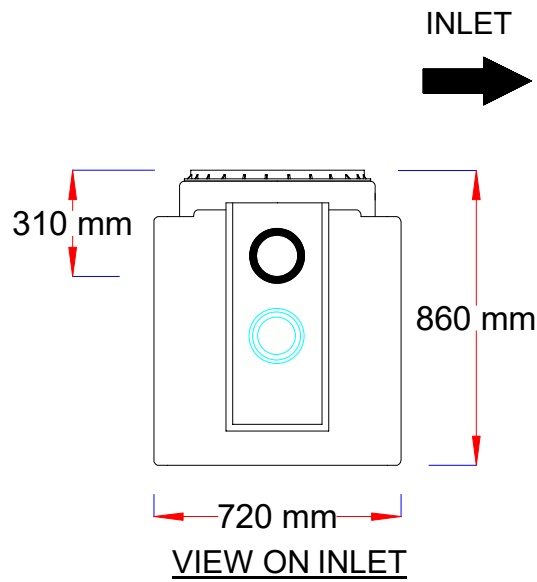

Oaklands Environmental Ltd
MOULDING A SUSTAINABLE FUTURE

© Oaklands Environmental Ltd 2017.
We reserve the right to change specification without prior notice in line with our policy of continuous development.
www.oaklandsenvironmental.com
PART OF THE OAKLANDS GROUP OF COMPANIES

REV	DETAIL	DATE	DRAWN
1	Base tank modified to Jumbo Midi®	01/09/17	gf

TITLE	Jumbo2 General Arrangement Drawing
CUSTOMER	

DRAWING NO	GA2155/12	DATE	06/06/2012	DRAWN	gf
THIRD ANGLE PROJECTION				SCALE	NOT TO SCALE
				SHEET	1 of 1
TOLERANCE +/- 2%				REV	1