

EXTENSION PARTS
(IF REQUIRED)
INCLUDED IN
PRODUCT CODE

NOTES

1. UNITS ARE SUPPLIED WITH THE STANDARD (MINIMUM) PIPEWORK SIZE, AND ORIENTATION SHOWN ON THE DRAWING. THE STANDARD EN858-1 STATES MINIMUM CONNECTION SIZES, UNITS ORDERED WITH DIFFERENT SIZE CONNECTIONS MAY NOT BE FULLY COMPLIANT WITH THE STANDARD. PLEASE CONSULT OUR SALES DEPARTMENT FOR DETAILS OF AVAILABLE OPTIONS, BUT PLEASE NOTE WE DO NOT ALTER INTERNAL PIPEWORK.
2. ALL UNITS SUPPLIED ARE CLASS 1 AND INCLUDE A COALESCER.
3. EXTENSION PARTS FOR DEEPER INVERTS CAN BE PROVIDED FOR ON SITE ASSEMBLY.
4. ALL UNITS REQUIRE APPROPRIATE CONCRETE BASE, COVER AND FRAME TO SUIT APPLIED LOADINGS.
5. THIS DRAWING SHOULD BE USED FOR DIMENSIONAL INFORMATION ONLY.
6. A Ø76mm TUBE IS SUPPLIED TO HOUSE AN OIL ALARM PROBE.

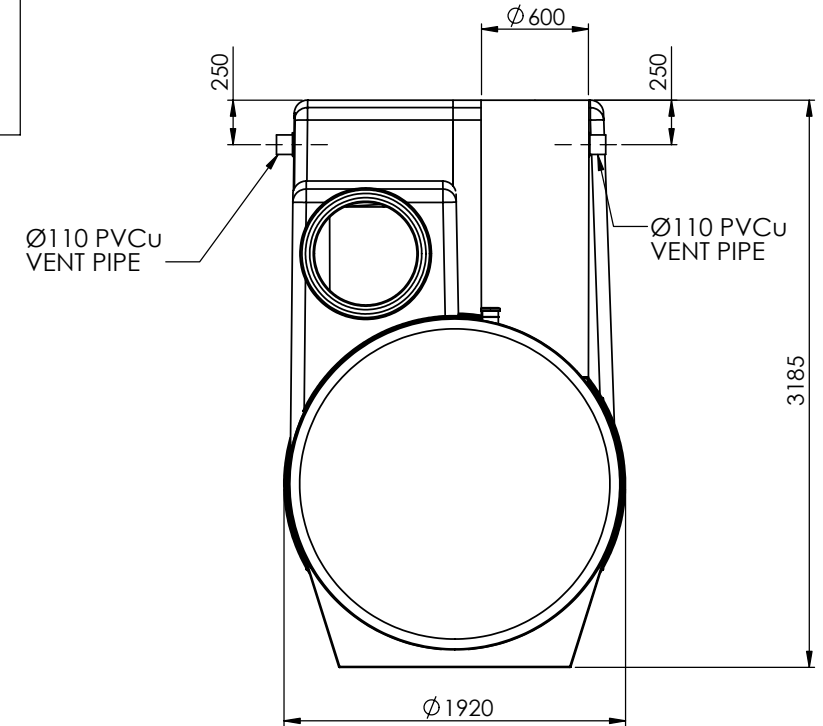
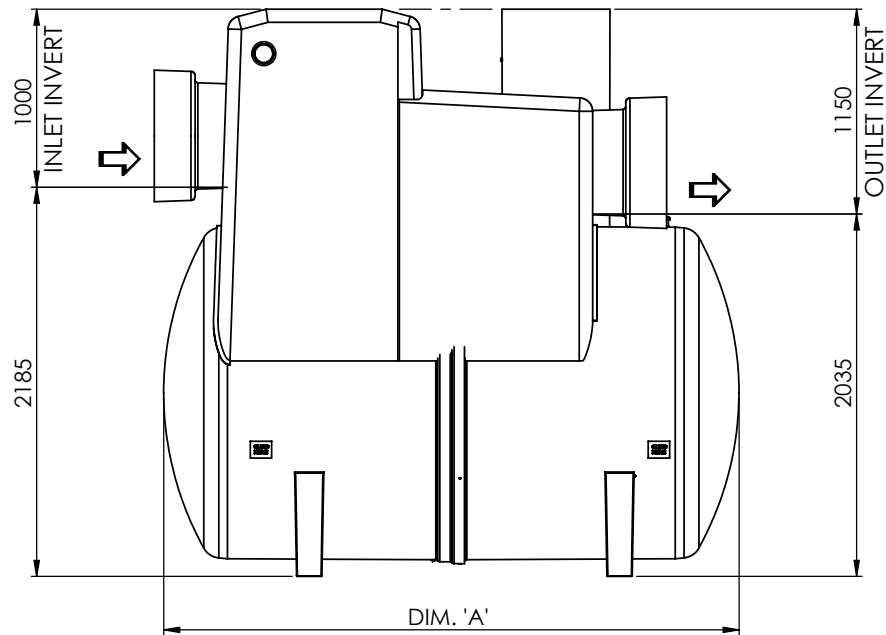

UNIT	NOMINAL FLOW (l/sec.)	DIM.'A'	DIM.'B'	DIM.'C'	STD. PIPE Ø	APPROX. EMPTY WEIGHT (kg)	FALL ACROSS UNIT
NSBE040	40.0	3230	902	1300	500	713	150
NSBE050	50.0	3960	1243	1325	600	782	150

Please Check with Environmental Treatment Systems Limited For The Latest Issue Of This Drawing				Description	
Issue	Date	Drawn by	Approved by		
01	03.03.14	T.Kelly		CC981 Phase 3 - Sales Release	

Material : Various	Tolerance (unless stated) :
Finish :	Thickness : n/a
Weight : 608.07 Kg	Surface Area : m ²
Modelled By : Name	

Drawing : DS1224 Page 1 of 2

NSBE040 & NSBE050 Bypass Separators

All Dimensions In mm Scale: Do Not Scale

Third Angle Projection

R:\Drawing Data\02 - Sales Drawings\DS\DS - 12\DS1224

Kingspan Environmental reserve the right to alter the details of this drawing without prior notice. This drawing is copyright and may not be reproduced or used without the written permission of Kingspan Environmental



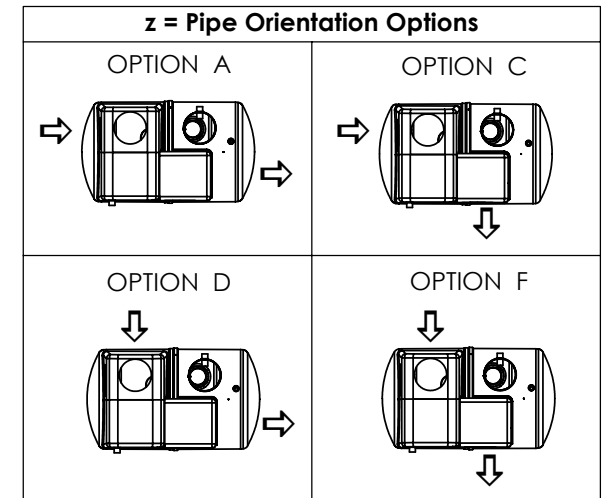
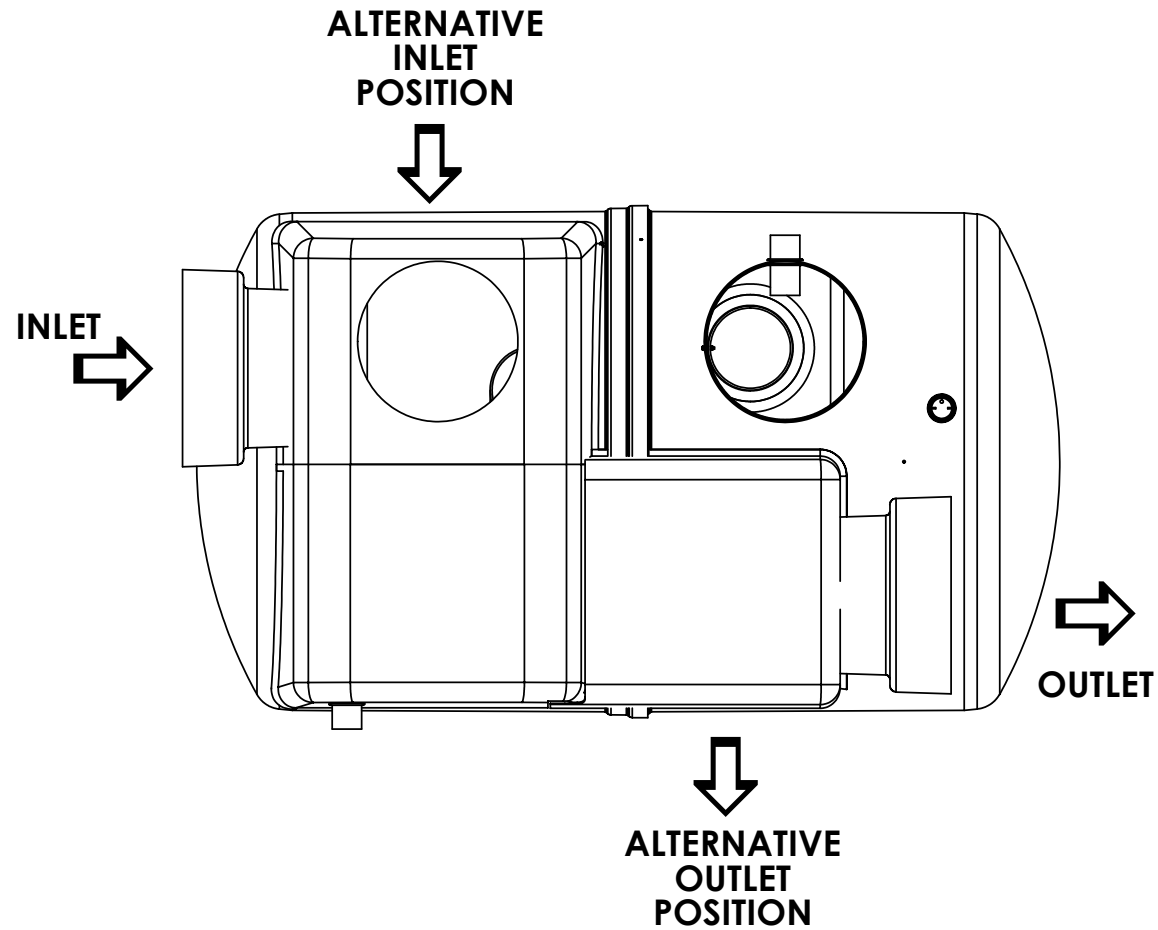

Material : Various	Tolerance (unless stated) :	Drawing : DS1224	Page 2 of 2
Finish :	Thickness : n/a		
Weight : 608.07 Kg	Surface Area : m ²		
Modelled By : Name			

All Dimensions In mm

Scale: Do Not Scale

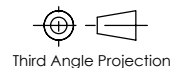

Kingspan Environmental reserve the right to alter the details of this drawing without prior notice. This drawing is copyright and may not be reproduced or used without the written permission of Kingspan Environmental

