

UNIT	DIM 'A'	DIM 'B'	DIM 'C'	WORKING CAPACITY	APPROX WEIGHT	FALL ANGLE
				EMPTY	FULL	
W/3/020	2074	550	500	2000 Litres	2220 Kg	50
W/3/030	2952	550	900	3000 Litres	3200 Kg	50
W/3/040	3898	750	1200	4000 Litres	4180 Kg	50

- NOTES :-
- UNITS CAN BE PROVIDED WITH EXTENSION SHAFTS IN 0.5Mtr INCREMENTS.
 - STANDARD INLET/OUTLET PIPES ARE PVCu UNDERGROUND DRAINAGE TO BS4680, FOR OTHER PIPE SIZES AND TYPES AVAILABLE CONSULT KARGESTER.
 - IT IS ESSENTIAL THAT THIS DRAWING IS READ IN CONJUNCTION WITH THE DATA SHEET (SUPPLIED WITH UNIT) GIVING INSTALLATION DETAILS. THIS DRAWING SHOULD BE USED FOR DIMENSIONAL INFORMATION ONLY

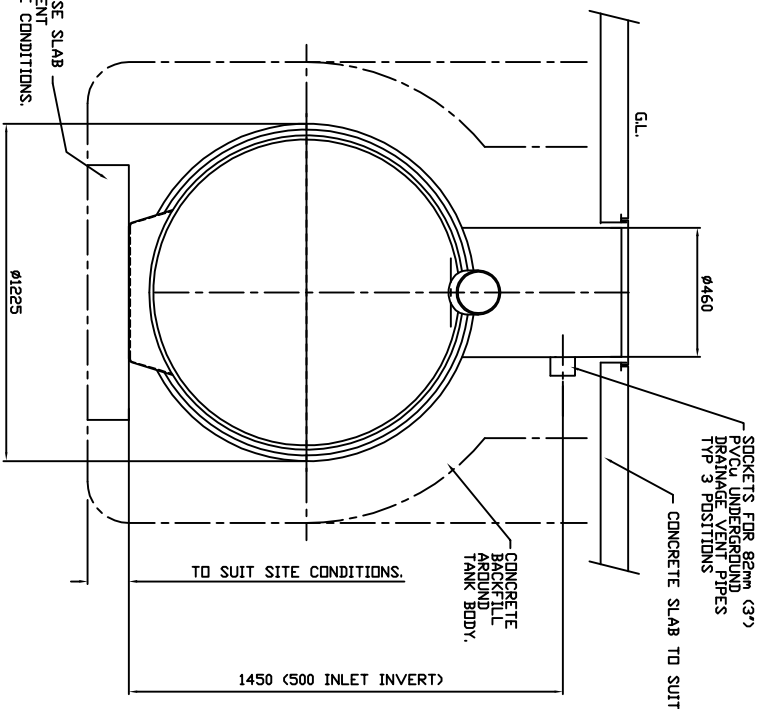
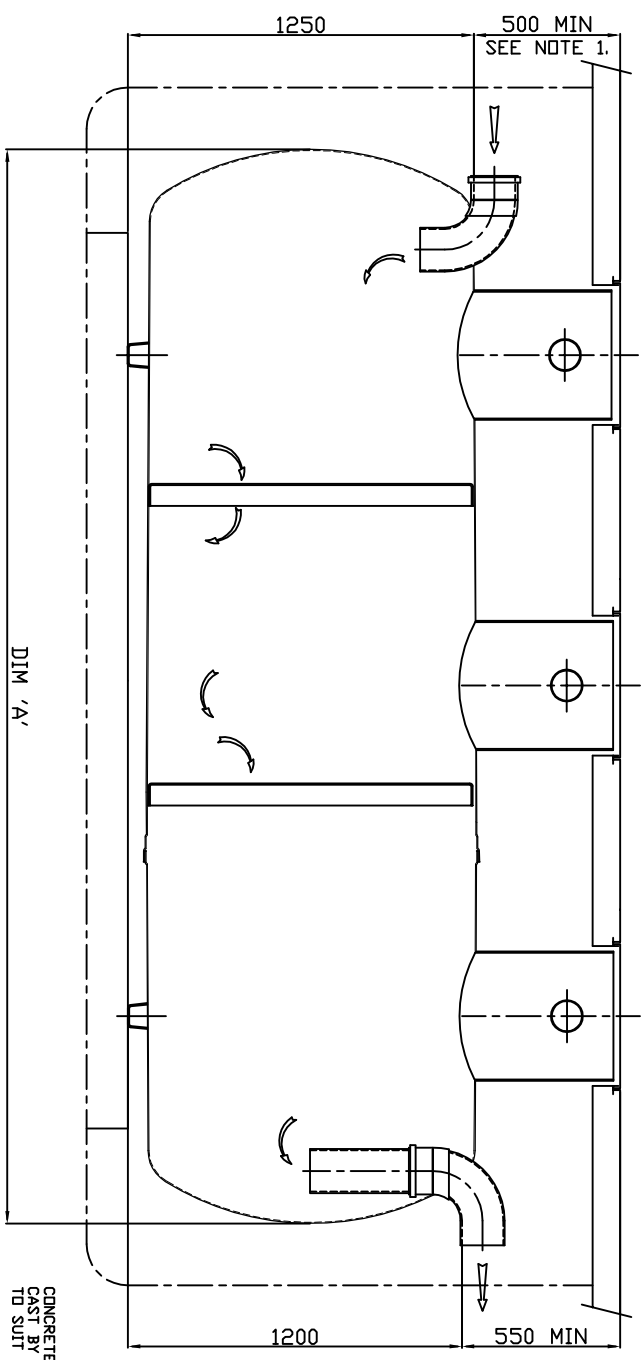

DIM 'A'
SECTION DN C.L.

ISSUE	DATE	BY	CHKD	DESCRIPTION
2	17/07/12	L.S	CC/061	
1	02.03.09	J.C	CC/702	

This drawing is copyright and may not be reproduced or used without the written permission of Kingspan. KINGSKAN RESERVE THE RIGHT TO CHANGE SPECIFICATIONS WITHOUT NOTICE

Kingspan
Environmental

ALL DIMENSIONS ARE IN MILLIMETRES - DO NOT SCALE

TITLE: W/3/020 - W/3/040 WASH DOWN & SILT SEPARATORS (3-STAGE)

SCALE: 1:10 SHEET SIZE: A1

DRAWING No: DS0834P ISSUE: 2