

Notes:

- Population Equivalent 50 Person
- Hydraulic design flowrate 9.0 m<sup>3</sup>/day
- BOD Loading 3.0 kg
- Media 500 m<sup>2</sup>
- Aeration Tubular membrane diffusers
- Compressor EL250 Electromagnetic air pump
- Power supply 230/1/50
- Recommended service interval 6 Monthly inspection including de-sludging as appropriate
- Inlet/outlet connections 160 Ø

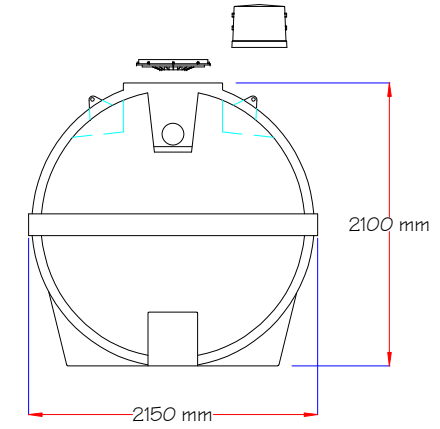
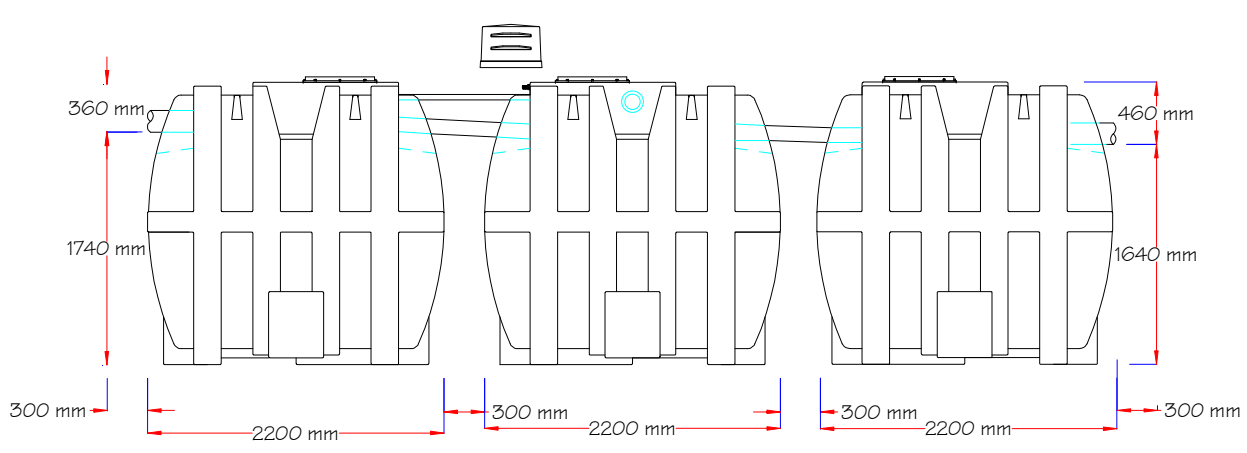

Oaklands Environmental Ltd  
 Unit 5b Eastway  
 Rivergreen Industrial Estate  
 SUNDERLAND  
 Tyne & Wear SR4 6AD  
 Tel: 00 44 (0)191 415 9090  
 Fax: 00 44 (0)191 565 2946  
[www.oaklandsenvironmental.co.uk](http://www.oaklandsenvironmental.co.uk)  
 PART OF THE OAKLANDS GROUP OF COMPANIES

REV	DETAIL	DATE	DRAWN
1	Rebranded as OM50	09/11/10	gf
2	DWF Channel amended	02/08/11	gf

TITLE  
 OM50 GA Drawing  
 CUSTOMER

DRAWING NO	DATE	DRAWN
GA2033/10	01/04/2010	gf
THIRD ANGLE PROJECTION		SCALE
		NOT TO SCALE
TOLERANCE +/- 2%		SHEET
		1 of 1
		REV
		2