

© H2O Group Ltd 2008. We reserve the right to change specification without prior notice in line with our policy of continuous development.

Notes:

- Population equivalent: 6 person
 - Hydraulic design flowrate: 1080 litres/day
 - BOD Loading: 0.36 kg/day
 - Media: 78.75 m²
 - Aeration: Tubular membrane diffuser
 - Compressor: EL60 Electromagnetic air pump
 - Power supply: 230/1/50
 - RCB: 16 amp
 - Recommended service interval: 6 month inspection including de-sludging as appropriate
 - Minimum excavation length: 4200 mm
- Unit includes 3 no 450 Ø clear access pedestrian rated cover and 1 no HDPE compressor housing

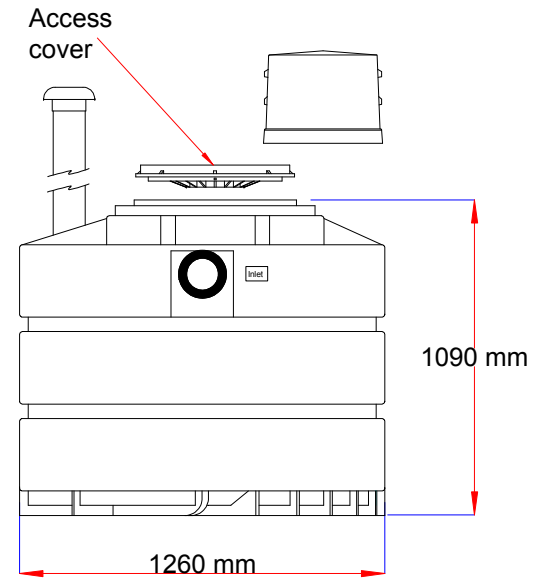
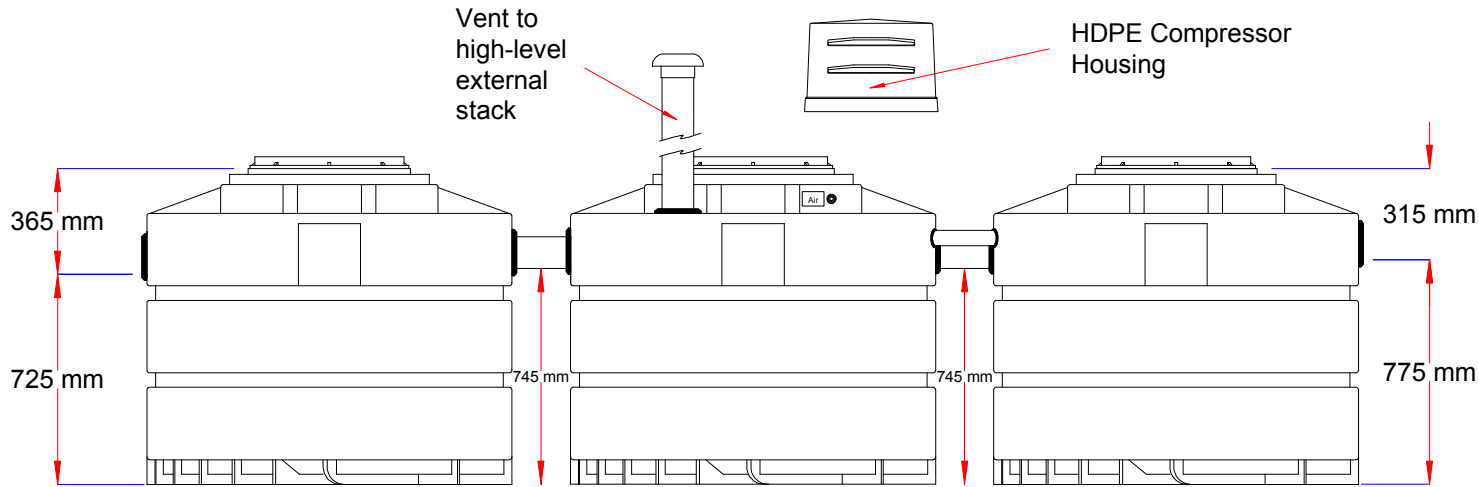
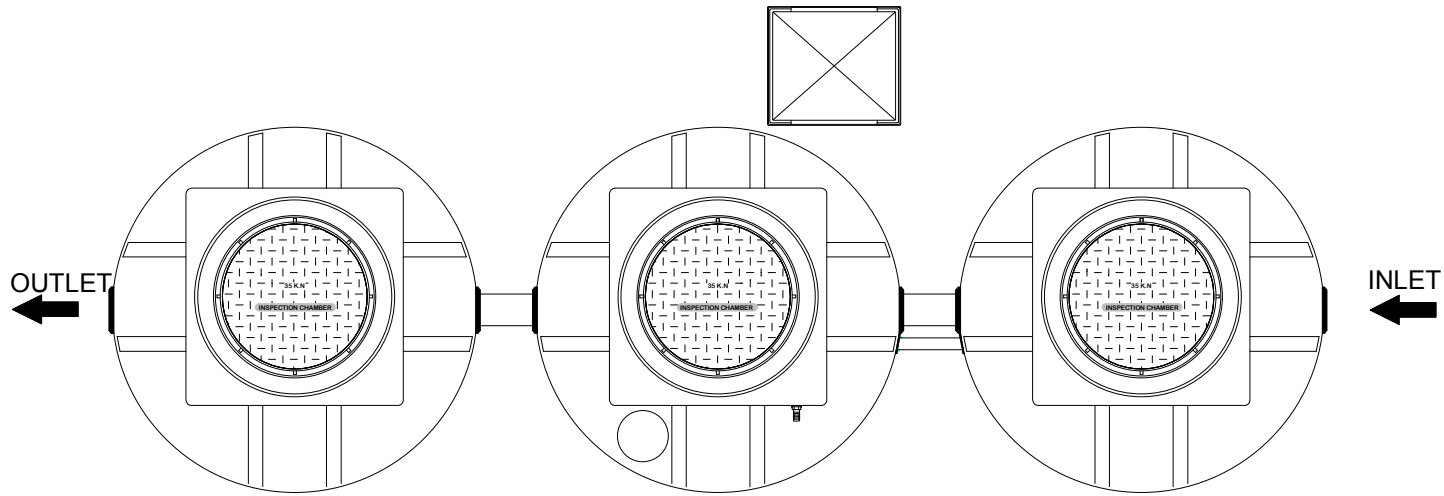

Oaklands Environmental Ltd
 Unit 5b Eastway
 Rivergreen Industrial Estate
 SUNDERLAND
 Tyne & Wear SR4 6AD
 Tel: 00 44 (0)191 415 9090
 Fax: 00 44 (0)191 565 2946
www.oaklandsenvironmental.com
 PART OF THE OAKLANDS GROUP OF COMPANIES

REV	DETAIL	DATE	DRAWN
1	Ribbed base added	13/09/10	gf
2	Rebranded as OM6LP	09/11/10	gf

TITLE	OM6LP Modulus shallow excavation treatment plant general arrangement drawing
CUSTOMER	

DRAWING NO	GA2001/08	DATE	27/11/2008	DRAWN	GF
THIRD ANGLE PROJECTION				SCALE	NOT TO SCALE
				SHEET	1 of 1
				REV	2
TOLERANCE +/- 2%					