

USE :

Water loaded with solids and fibers
 All wastewater from homes, including toilets.
 Front outlet is ideal for installations with guide rail
 Immersion depth of 10 m

FEATURES :

Protection box in monophasic version
 Grinder system, impeller in cast iron,
 stainless steel shaft, motor body inox on GR and cas iron on SGR
 Engine oil bath class F
 Double seals, lip seals and reinforced carbon ceramic mechanical seal
 Single-phase models with or without float float (type A)



SEWAGE
Grinder

**Submersible
 Pump for Sewage
 Water With Grinder**

Grinder ■.....

Grinder

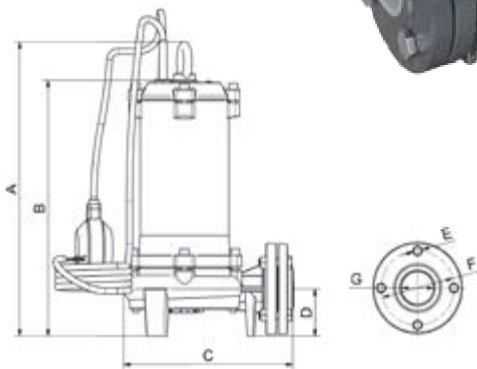
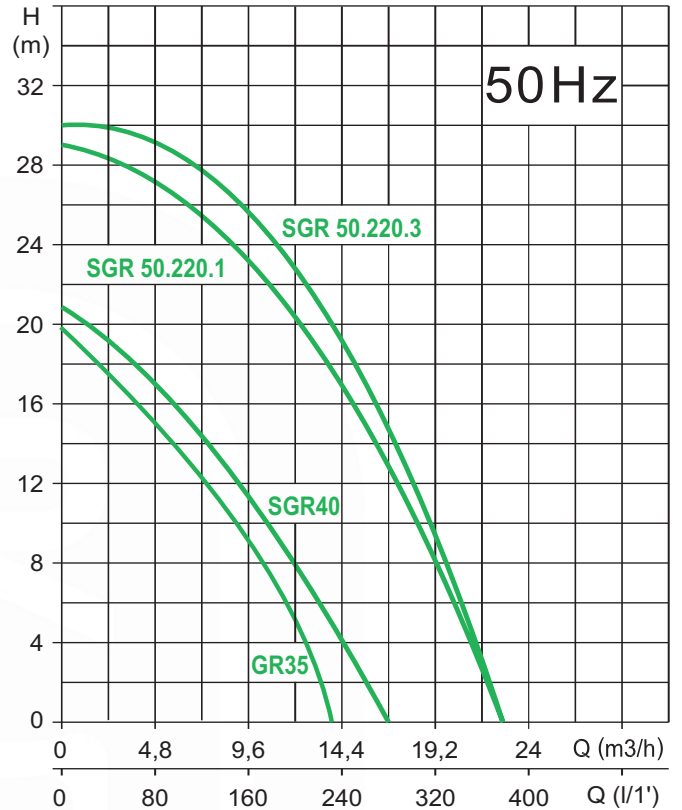

Type	Dimensions (mm)							Weight Kg
	A	B	C	D	øE	øF	G	
GR 35.150	416	366	200	76	10	86	1 1/4	18
GR 35.120	396	346						18
SGR 40.150	404	352	237	65	11	102	1 1/2	26,5
SGR 40.120								26,5
SGR 50.220	470	415	294	95	13	110	2"	36

Type	Power		Motor			Connection DN	H (max) m	Debit (max) m³/h	Code		
	kW	CV	1~ A	μF	3~ A				1x230v (.1M)	1x230v (.1A)	3x400v (.3)
GR 35.150	1,5	2	8,7	35	-	1 1/4	20	13,8	01010989	01010990	---
GR 35.120	1,2	1,6	-	-	2,8				---	--	01010991
SGR 40.150	1,5	2	7,2	35	-	1 1/2	21	16,5	01011031	01011032	--
SGR 40.120	1,2	1,6	-	-	2,1				--	--	01011033
SGR 50.220	2,2	3	10	40	4,6	2	30	32,2	01011074	--	01011061

Power cable: 10 m neoprene for GR and SGR 40, 20m neoprene for SGR 50 - Type A: model with float switch