



Installation & Maintenance Instructions

For rainwater harvesting systems
Including:

- Garden Economy
- Garden Premium
- Direct Pressure

Introduction

Receipt of goods ...



1. Deliveries to site will be organised in conjunction with Site Agents to ensure that arrangements have been made for their safe receipt; Site Agents are advised to ensure that all goods are thoroughly checked on receipt against delivery documentation as items later reported as missing or damaged cannot be replaced and will need to be re-ordered.



2. It should particularly be noted that the condition of the rainwater harvesting systems becomes the responsibility of the Site Agent once unloaded from the delivery vehicle.

Installation overview ...

3. If supervising the installation of a RWH system for the first time, it should be planned to undertake the work in the following stages:

- ⇒ Review general operating principles *see page-3*
- ⇒ Review components of the system to be installed:
 - ✓ Parts supplied (schematic drawings) *see page-5*
 - ✓ Pump specification *see page-7*
 - ✓ Filters *see page-11*
 - ✓ Tank connections *see page-13*
- ⇒ Installing the components:
 - ✓ Overview *see page-14*
 - ✓ Garden Economy *see page-15*
 - ✓ Installation sequence *see page-16*
 - ✓ Garden Premium *see page-17*
 - ✓ Installation sequence *see page-18*
 - ✓ Home & Garden Direct Pressure Service *see page-19*
 - ✓ Installation sequence *see page-20*
 - ✓ Top Up Controller *see page-21*
- ⇒ Commissioning *see page-20*
- ⇒ Using the system:
 - ✓ Handing-over *see page-29*
 - ✓ Safety & access *see page-29*
 - ✓ Routine maintenance & fault-finding *see page-30*
 - ✓ Water quality *see page-30*
- ⇒ Terms of business *see page-31*

Health & safety ...



4. All Health & Safety precautions applying to such works are to be implemented, with risk assessments and method statements being prepared.

General Operating Principles

System components ...

- Understanding the operating principles of RWH systems is essential to ensure their successful installation; the diagram below shows the typical schematic layout of a rainwater harvesting system which supplies water under pump pressure direct from the water storage tank, usually referred to as the “direct pressure” system:

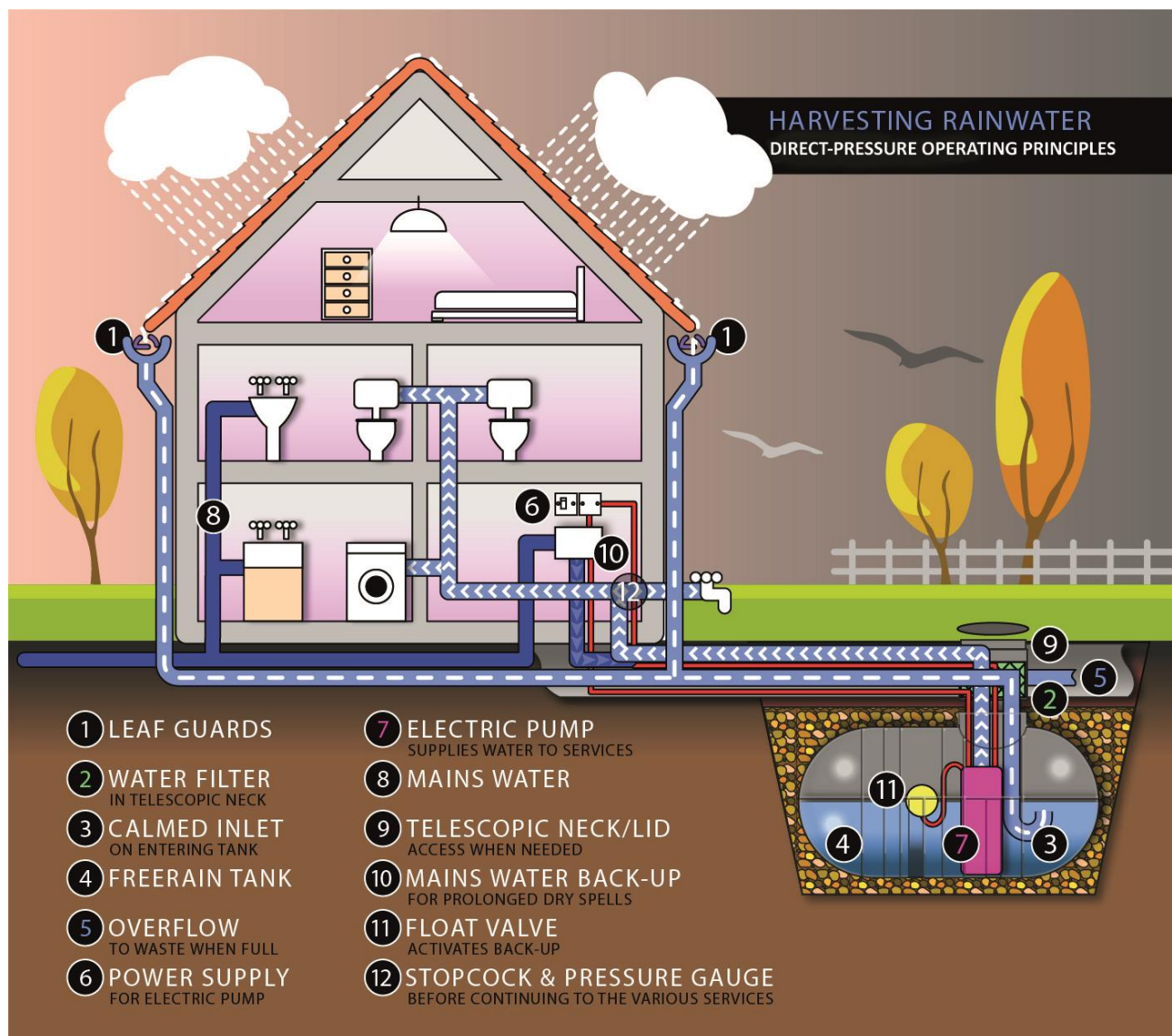

Points to Note:



- The main storage tanks need to be able to overflow to a soak-away or storm-drain which must be adequate to cope with the rate of flow to avoid contaminated water back-flowing into the storage tank**
- Mains water supply to provide top-up, when needed during long dry spells, must be via a Class-AA tun-dish air-gap in a direct-pressure system**
- Supply to services must be via dedicated pipe-work; which must not be cross-connected to the mains pipe-work**

Working principles ...

6. Domestic systems must use only the property roof for collecting the rainwater which is then stored in an underground tank to provide non-wholesome water for toilet flushing, clothes washing machines, and the outside tap.
7. Collection from a conventional roof is recommended, avoiding “green” and sedum roofs. The roof water is channelled through the normal guttering and down-pipe arrangements, before being brought into a single drainage pipe underground which feeds into the storage tank.
8. In accordance with the requirements of BS 8515 & BS EN 16941-1:2018, the water is filtered before entering the storage tank to remove solid particles, usually using a stainless-steel filter installed in the neck of the tank. This filter requires cleaning every 3 months to maintain its efficiency. Failure to do so will possibly lead to progressive clogging of the filter, causing incoming water to be lost direct to the overflow, rather than entering the tank.
9. Having passed through the filter, the water is introduced into the tank via a calmed inlet designed to smoothly introduce the fresh and highly oxygenated rainwater into the bottom of the tank. This helps to avoid stagnation at the lowest level and assists maintenance of the quality of the water stored in the tank.
10. The stored water is then supplied to the non-wholesome services on-demand; this demand is sensed, by either a Control Unit or the pump itself, which activates the durable electric pump in the tank to meet the demand. When the demand for the water supply ends, this too is sensed and the pump stops. Under this “direct pressure” arrangement, the pump is effectively linked direct to the service concerned
11. In periods of prolonged rain, the storage tank will become full and overflow through the connection provided to the surface water management arrangements for the project (ie soak-away, storm drain or attenuation system) and can be protected from back-filling by a back-flow prevention valve if connected to a sewer – for further info, speak to our sales team. As the water storage tank may already be full when a heavy downpour is experienced, the whole of the tank volume cannot be taken into account when making the attenuation calculations for the project.
12. Conversely, in dry spells the tank contents may be in danger of becoming exhausted and need to be supplemented by mains water to ensure continuity of supply to the services. This too is sensed by the Control Unit which then activates a solenoid valve to allow mains water to enter the tank via a Class-AA air-gap; this prevents direct contact between the wholesome and non-wholesome pipe-work/water. Only a limited amount of water is introduced in this way, so leaving the maximum possible capacity for the next rainfall.

Irrigation-only systems ...

13. Direct pressure systems are also used when systems are purchased solely for garden-irrigation purposes, manufactured and supplied by Puratank.
14. These operate on the same principles noted above, but are not fitted with a mains-water backup as this would make them subject to hose-pipe bans. Further information is provided below.

System Components

Parts & components & how they relate ...

15. Schematic layouts of the Puratank systems are laid out below for the Garden Eco, Garden Premium and the Home & Garden Direct Pressure systems. Each diagram can also be used to check full delivery of all system components:

Garden Eco ...

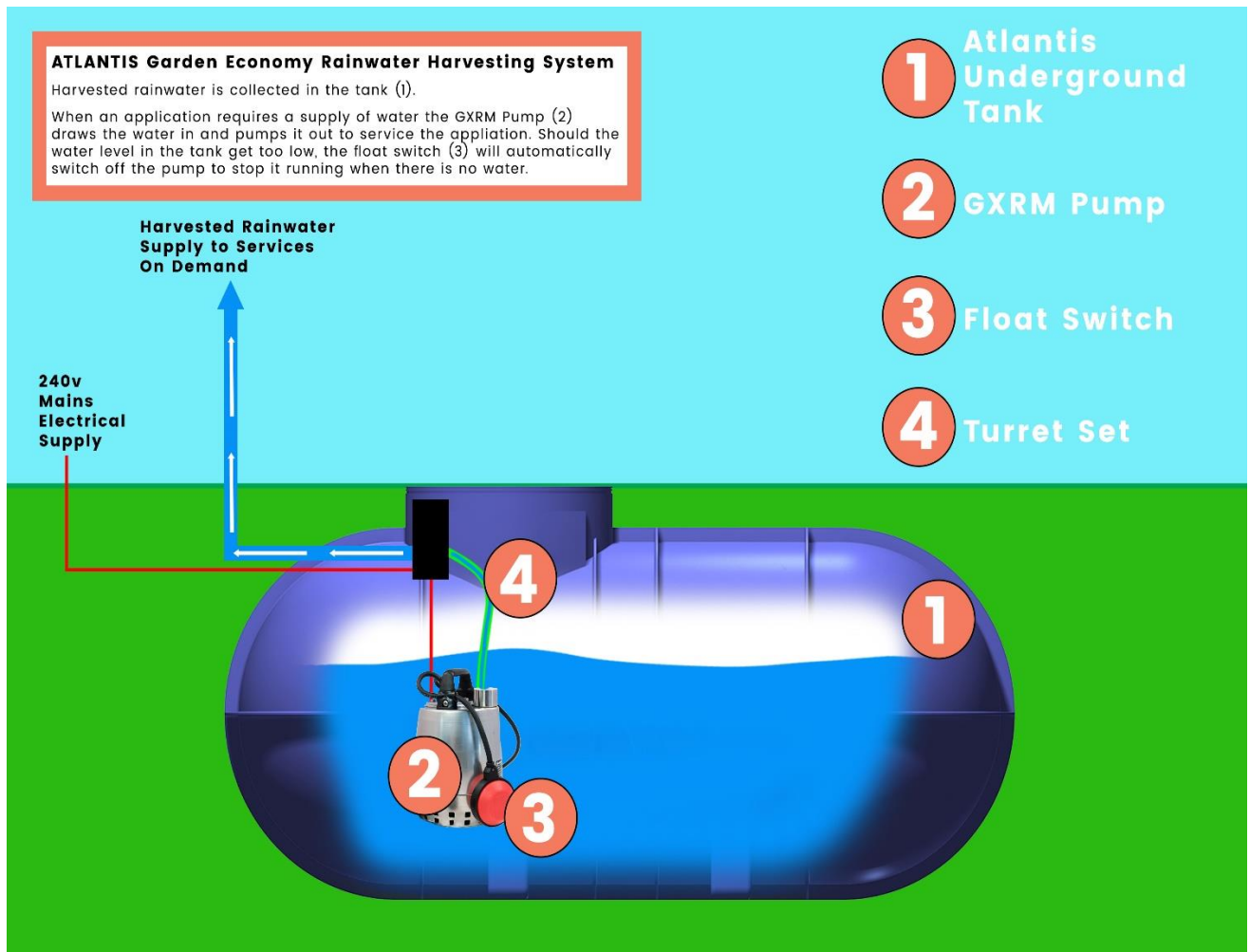

Garden Premium ...

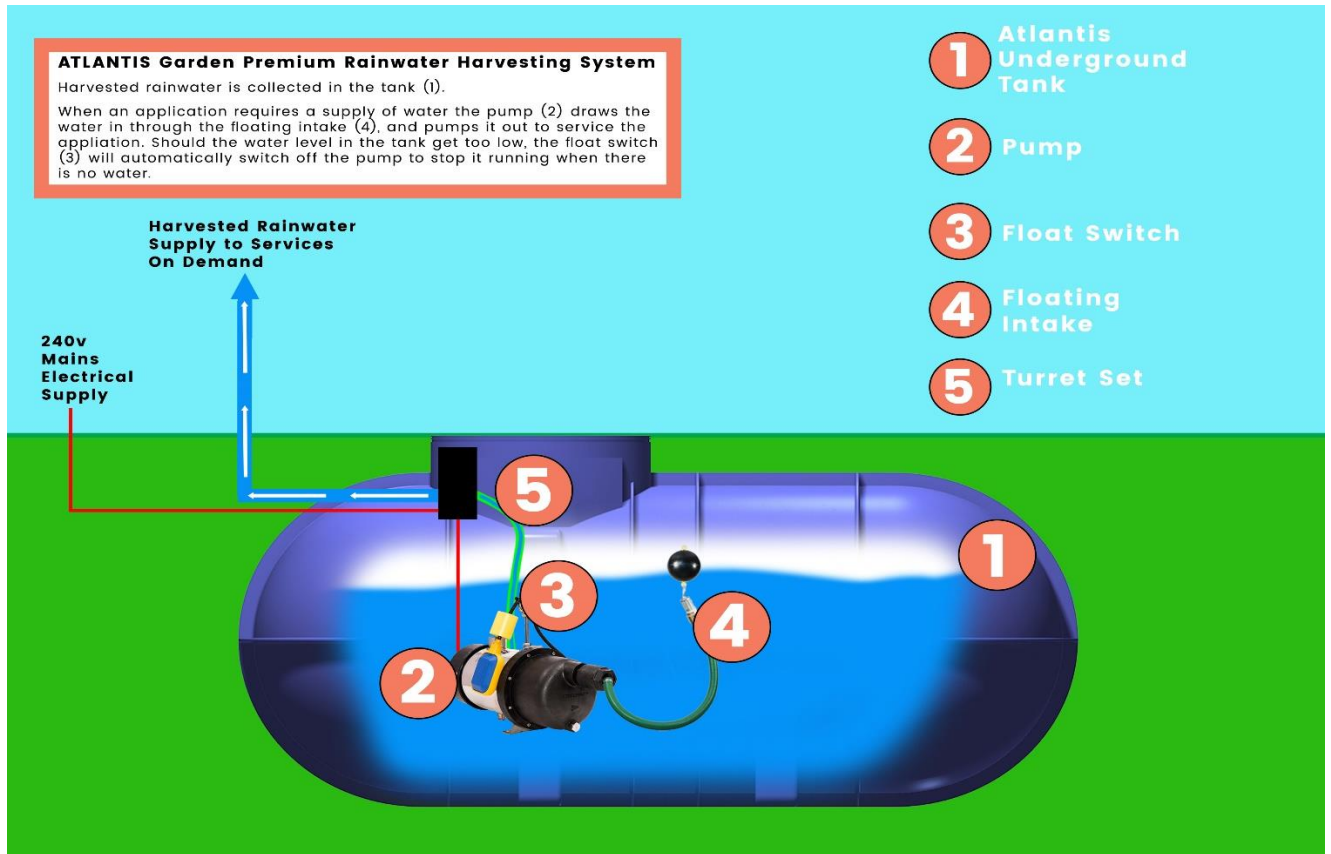

Home & Garden Direct Pressure ...

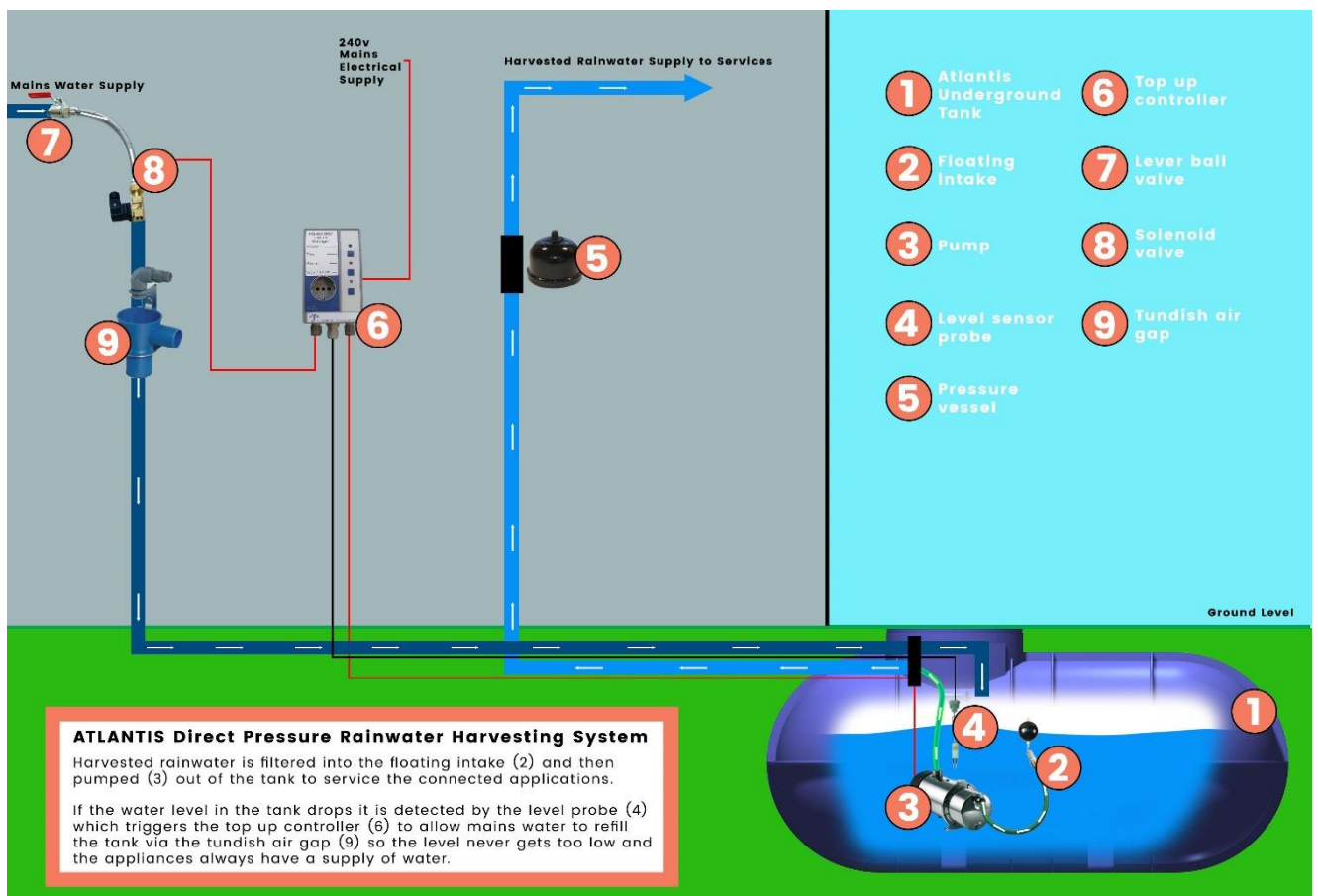

Pumps ...

16. There are 3 types of pumps supplied with the Puratank systems. These are the Calpeda GXR pump for the Garden Eco, the Steelpumps X-AJEP pump for the Garden Premium and the Steelpumps X-AJEB pump for the Home & Garden Direct Pressure systems. These are all submersible pumps. The specifications of each pump are as below:

GXR pump for Garden Economy ...

GXR, GXV

Submersible Pumps
in stainless steel



Construction

Single-impeller submersible pumps in chrome-nickel stainless steel, with vertical delivery port.

GXR: with open impeller.

GXV: with free-flow (vortex) impeller.

Motor cooled by the pumped water passing between the motor jacket and the external jacket.

Double shaft seal with oil chamber.

Applications

GXR: - For clean water containing solids up to 10 mm grain size.
- For draining rooms or emptying tanks.
- Extraction of water from ponds, streams or pits and for rainwater collection.
- For irrigation purposes.

GXV: - For clean or slightly dirty water, containing solids up to 25 mm grain size.

- Particularly suitable for liquids with a high solid content.

For outdoor use a power supply cable of not less than 10 m should be used in accordance with: EN 60 335-2-41.

Operating conditions

Liquid temperature up to 50° C.

Maximum immersion depth: 5 m.

Minimum water level with float: GXR = 70 mm, GXV = 130 mm.

Minimum water level manual operation: GXR = 15 mm, GXV = 30 mm.

Continuous duty.

Motor

2-pole induction motor, 50 Hz (n = 2900 rpm).

GXR, GXV: three-phase 230 V ± 10%;

three-phase 400 V ± 10%;

GXRM, GXVM: single-phase 230 V,
with float switch and thermal protector.
Incorporated capacitor.

Insulation class F.

Protection IP X8 (for continuous immersion)

Double impregnation humidity-proof drying.

Constructed in accordance with: EN 60034-1;

EN 60335-1, EN 60335-2-41.

Materials

Component	Material
Pump casing	Chrome-nickel steel 1.4301 EN 10088 (AISI 304)
Strainer	
Impeller	
Motor jacket	
Pump jacket	
Handle	Polypropylene
Shaft	Chrome-nickel steel 1.4305 EN 10088 (AISI 303)
Mechanical seal	Ceramic alumina/Carbon/NBR
Seal lubrication oil	Oil for food/pharmaceutical machinery

Other features on request

- Other voltages. - Frequency 60 Hz. - Other mechanical seal. - Cable length 10 m.
- Vertical magnetic float switch. - Motor suitable for operation with frequency converter.

Characteristic curves n ≈ 2900 rpm

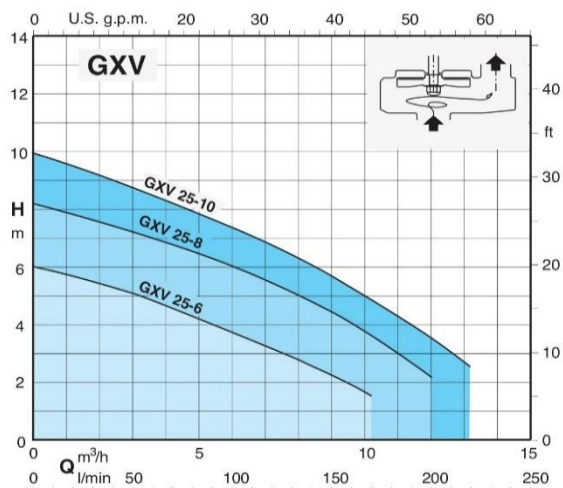
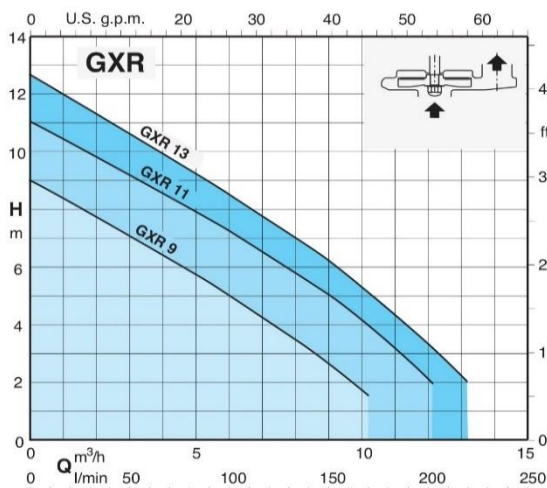

GXR, GXV

Submersible Pumps
in stainless steel



Features

PATENTED

G 1 1/4 vertical, upward delivery port for installation in small pits, without the need for an elbow on the pump.

Minimum dimension and high levels of performance, for use in many different applications, head up to 12,7 m and flow rates up to 220 liters/min.

Easy adjustment of the float switch: to allow the adjustment of start/stop pump levels.

Suction strainer with a double row of holes, for extra safety against clogging.
GXV: it allows the passage of solids up to 25 mm.

Handle in polypropylene.

Easy inspection of the capacitor area.

Shaft in chrome-nickel stainless steel.

Motor cooled by the pumped water passing between the motor jacket and the external jacket.

Ceramic stainless steel shaft sleeve.

Oil chamber.

Suction strainer with a double row of holes, for extra safety against clogging.
GXR: it allows the passage of solids up to 10 mm.

Impeller in chrome-nickel stainless steel.

The double shaft seal with oil chamber separates the motor from the water and provides further protection against accidental operation when dry.

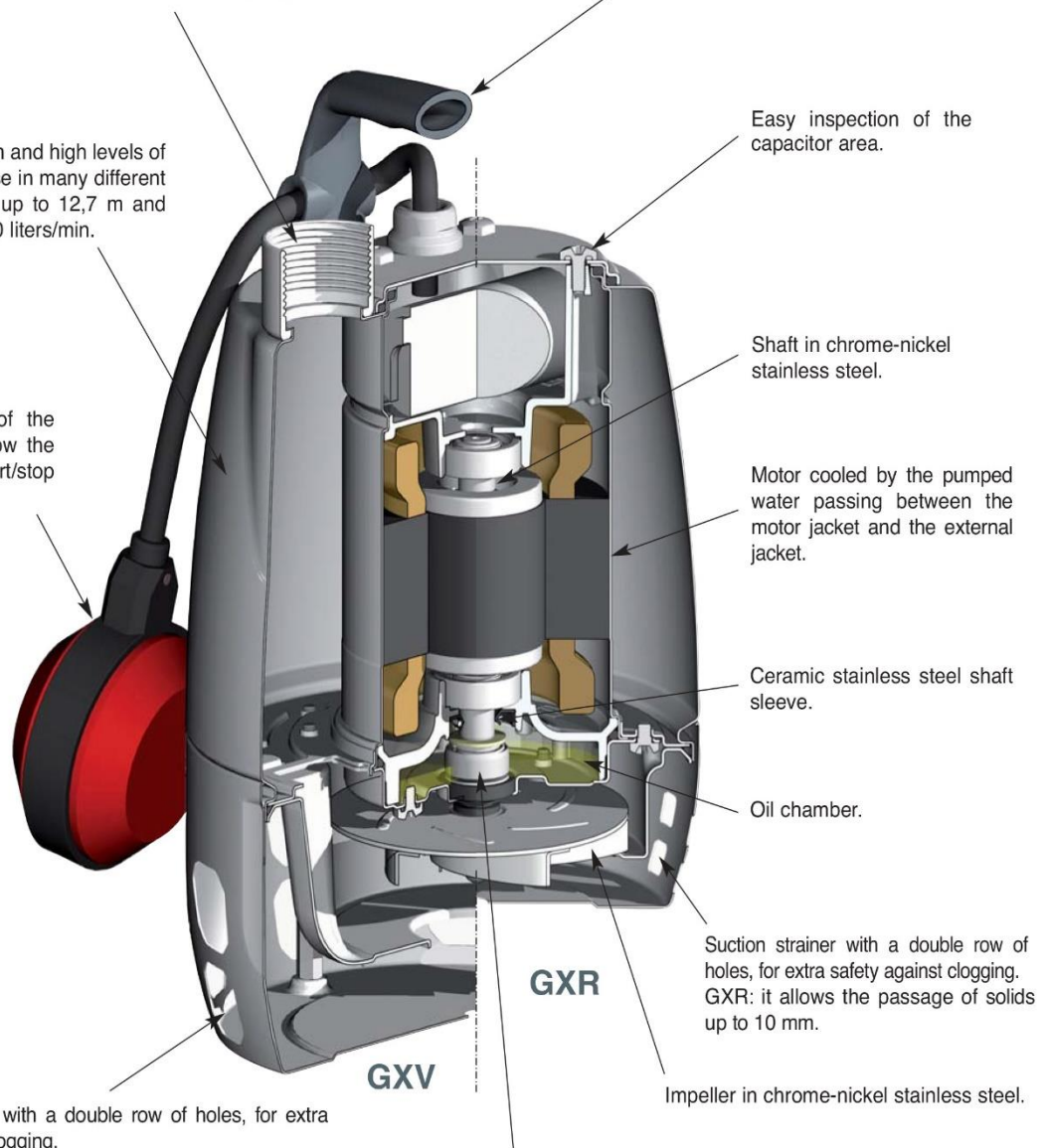

X – AJE80B Pump for Home & Garden Direct Pressure system ...

STEELPUMPS

EVOLUTION

X-AJE/JE B Series

Self priming centrifugal jet pump with or without electronic pressure control, single or 3 phase.

PLUS

UP/Down technology for submerged, surface or underground installation.
 Protection rating IP 68.
 Automatic version includes pressure control, anti-blocking system and dry run protection with automatic restart.

MATERIALS

- Motor body: Aisi 304
- Pump body: Aisi 304
- Rotor Shaft: Aisi 420
- Supporting flanges: Polypropylene
- Diffuser, Impeller and Venturi Jet: Noryl
- Rear cap: Polypropylene
- Basis: Aisi 304
- Mechanical seal: Silicon Carbide
- Mechanical seal lubricated by a special oil chamber
- A2 Stainless steel bolts
- NBR70 O-ring
- H07RN-F Electric cable 10m length with 3-Pin UK plug
- Tropicalized circuit board in compliance with the RoHS directive

ELECTRICAL FEATURES

Code	P2 Nom.		3~ 50Hz Amps		1~ 50Hz Amps	Cap. μ F
	KW	HP	230V	400V	230V	
X-AJE/JE 80B	0.6	0.8	2.2	1.5	4.5	16
X-AJE/JE 100B	0.75	1	3	1.9	5.3	16
X-AJE/JE 120B	0.9	1.2	3.6	2.3	6.3	18
Class F insulated motor			S1 Motor Service Factor			

HYDRAULIC FEATURES

Code	Q (l/m) FLOW						
	0	10	20	30	40	50	60
H HYDRAULIC HEAD (m)							
X-AJE/JE 80B	40	33	30	24	20	15	
X-AJE/JE 100B	47	40	35	30	25	20	5
X-AJE/JE 120B	49	43	38	32	30	24	8

CHARACTERISTICS AND INSTALLATION

Drained Liquid	Clean Water
Liquid temperature range	+2°C to +37°C
Air temperature	max +45°C
Maximum depth	5m
Calibrating pressure rate switch	1.5 bar

DIMENSIONS AND WEIGHTS

Code	Measurement (mm unless indicated)						Weight Kg
	A	N	H	H1	N1	DMN	
X-AJE/JE 80B	447	200	226	163	136	1"¼	11.5
X-AJE/JE 100B	447	200	226	163	136	1"¼	12
X-AJE/JE 120B	447	200	226	163	136	1"¼	13



PERFORMANCE CURVES

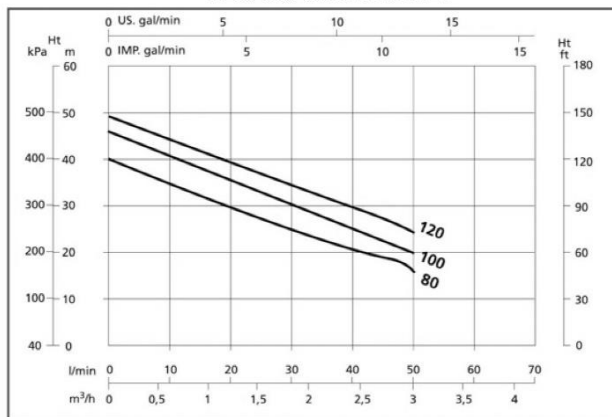

Efficiency

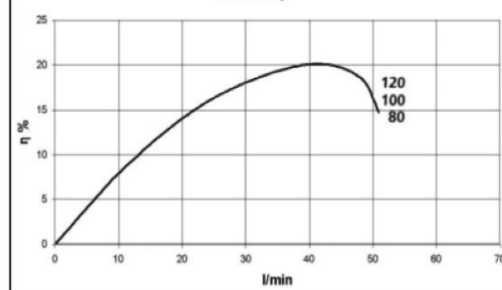

Power

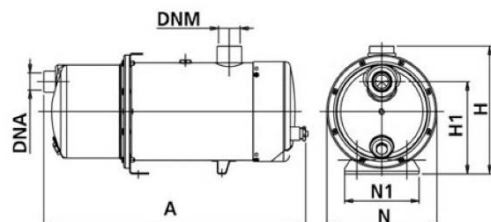
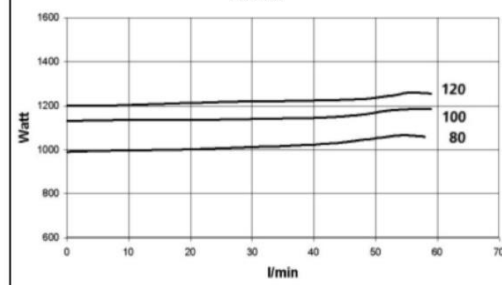

Filters ...

17. There are 3 main different types of filter depending upon your requirements and order. The most commonly used in Puratank systems is the Patronen filter. See the different types below:

Compact Filter

The Compact filter is particularly useful when there is a requirement for minimum/zero invert level drop between the inlet and the outlet.

The key technical characteristics of the filter are:

- ✓ Connection capacity for roof areas up to 150 m²
- ✓ All connections DN 100 (110mm OD).
- ✓ No height difference between inlet and outlet.
- ✓ Mesh size of filter cartridge 0.7 x 1.7 mm.

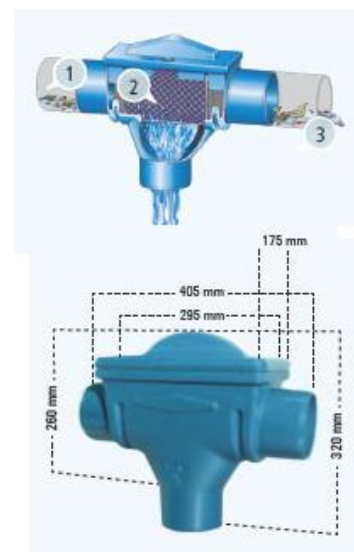

Patronen Filter

The Patronen Filter is one of the most popular in the Puratank range, for flow-rates associated with larger roofs, or where an invert drop across the filter is desirable. The PF filter works on similar principles to the Compact filter.

The key technical characteristics of the PF filter are:

- ✓ Connection capacity after DIN 1986 for roof areas up to 200 m².
- ✓ All connections DN 100.
- ✓ Small height difference of 66 mm between rainwater inlet and waste water outlet.
- ✓ Mesh size of filter cartridge 0.7 x 1.7 mm.

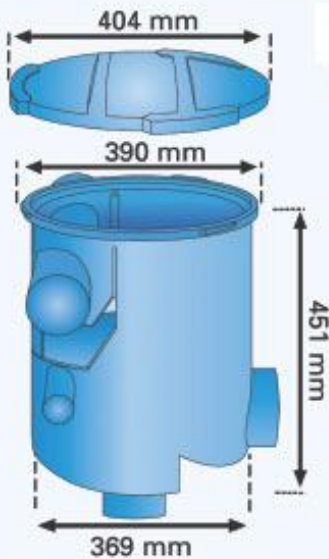

VF-1 Filter

Completing the range of filters most likely to be used on domestic-scale projects, the VF-1 filter would be most likely to be specified to complement the larger tanks in the Puratank range.

The key technical characteristics of the VF1-filter are:

- ✓ Suitable for connection to roof areas up to 500 m².
- ✓ Height difference between inlet and outlet 300 mm.
- ✓ Suitable in-tank installation as shown below
- ✓ Or can be provided with its own neck for installation pre storage tank



Puratank standard connection orientations ...

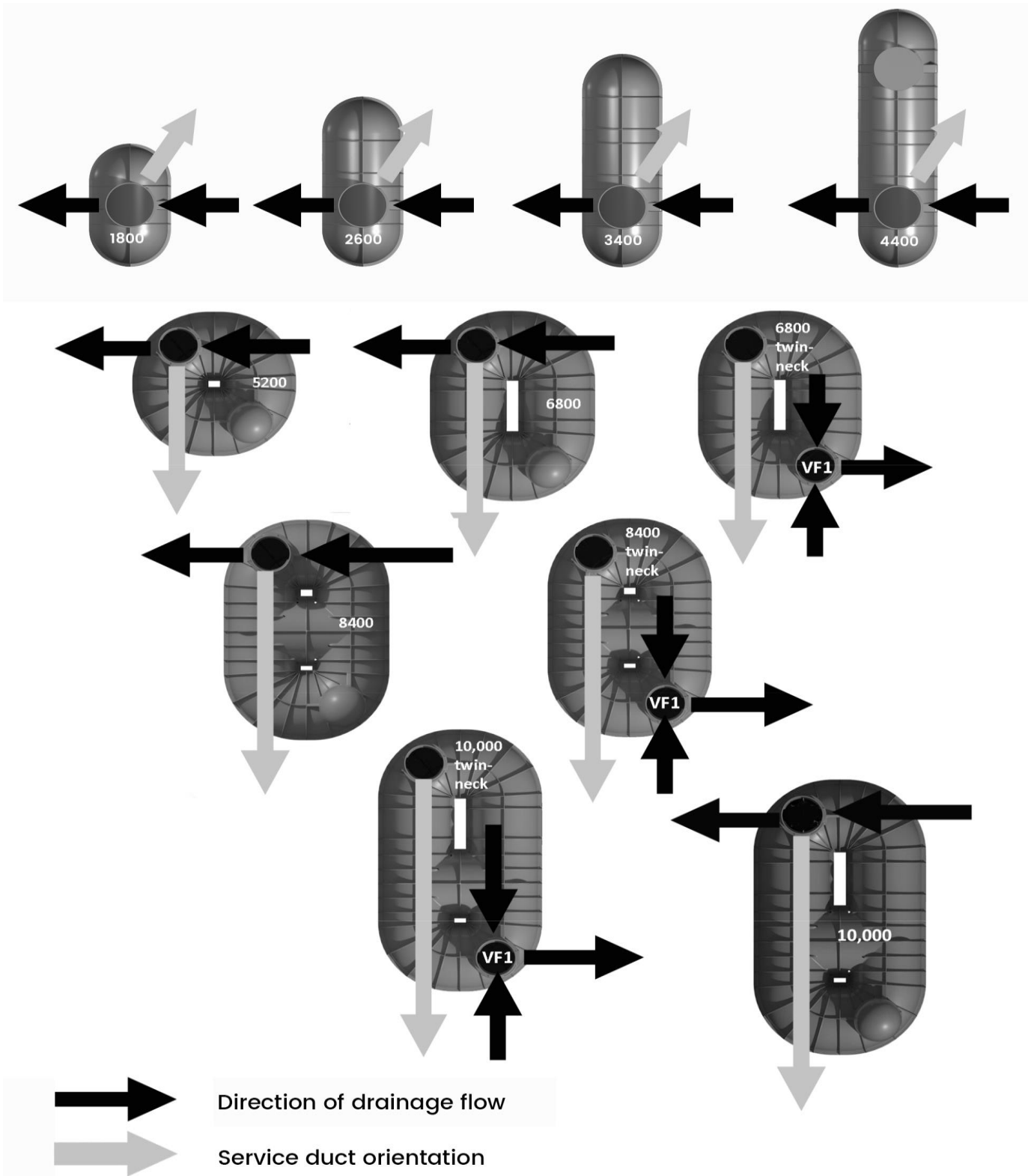

Buyer Notes:

1. Service-ducts need to be directly aligned with controls location
2. On direct-pressure systems, service-ducts must drain towards tank
3. Invert-drops across filters are CF-zero; PF-66mm; VF1-300mm

Installing The Other Components

Overview ...



18. The services to be supplied by the rainwater harvesting system (usually the toilets, the clothes washing machine and the outside tap) are to be fed by pipe-work that is independent of the mains water system, with no interconnections between the two except via the air-gaps provided for top-up purposes. Also, "Fluidmaster" valves are to be fitted to all cisterns.

19. The pipe-work conveying rainwater inside a building should ideally be plastic and be installed and tested for air-tightness at the 1st-fix plumbing stage. Outside the building, black High Performance Polyethylene (HPP) pipe-work marked with a green stripes along its length must be used in accordance with Annex-C to BS-8515 & BS EN 16941-1:2018.

20. Each system includes relevant signage and pipe-marking (where applicable) which must be used appropriately throughout the system, per the examples below:

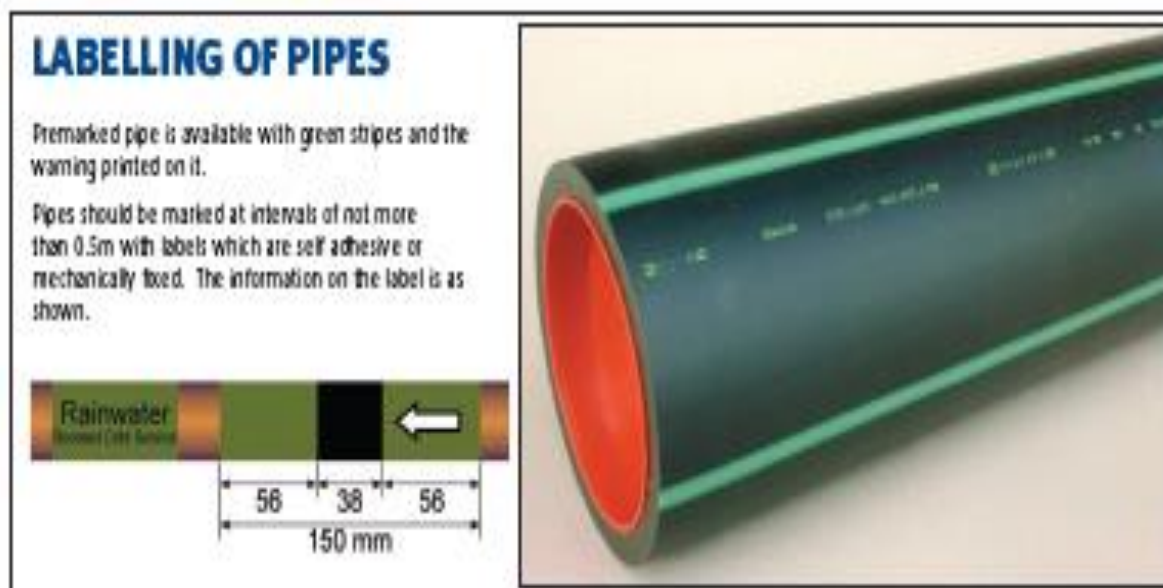

21. Other 1st fix tasks include making a 10-amp fused spur electrical and mains water supply available for connection when the remainder of the components are installed.
22. The 2nd fix work brings the system to a position where it is fully operational, and commissioned, ready to be handed-over.
23. The integrity of the services supply-side pipe-work is to be air-pressure tested, and all associated fixtures and fittings properly installed, before power is applied to the system.

The Three Main Systems

Garden Economy ...

The picture below shows the main parts supplied with this system kit. Some of these parts may already be pre-fitted to your tank. This picture can be used to identify and check the availability of all the parts on delivery:



Installation sequence for the Garden Economy system ...

24. See parts descriptions below:

1. The GXRM is a stainless steel submersible water pump c/w integral float switch to protect from dry running. This is an automatic on/off pressure sensing pump supplied separately and is lowered into the tank after installation. It is supplied with a long electrical connection cable and a length of rope is supplied to tie to the pump for ease of raising and lowering the pump for maintenance too. The pump has an integral strainer
2. The Rodent Guard is a very important feature preventing any unwanted rodents from entering the tank via the overflow. It is pre-fitted as standard and is located on the outlet part of the filter
3. The Patronen Filter – in addition to the details above, this is a self cleaning filter although regular inspection is recommended. This is pre-fitted to the tank prior to delivery
4. The Pump Turret is a flexible plastic/rubber connection supplied separately and is fitted to the pump before it is lowered into the tank. The top end (at neck height) can either be used to connect to an underground pipe or be fitted with a hose connector for simple garden use

The lid is shown here but is an optional extra.

Garden Premium ...

The picture below shows the main parts supplied with this system kit. Some of these parts may already be pre-fitted to your tank. This picture can be used to identify and check the availability of all the parts on delivery:

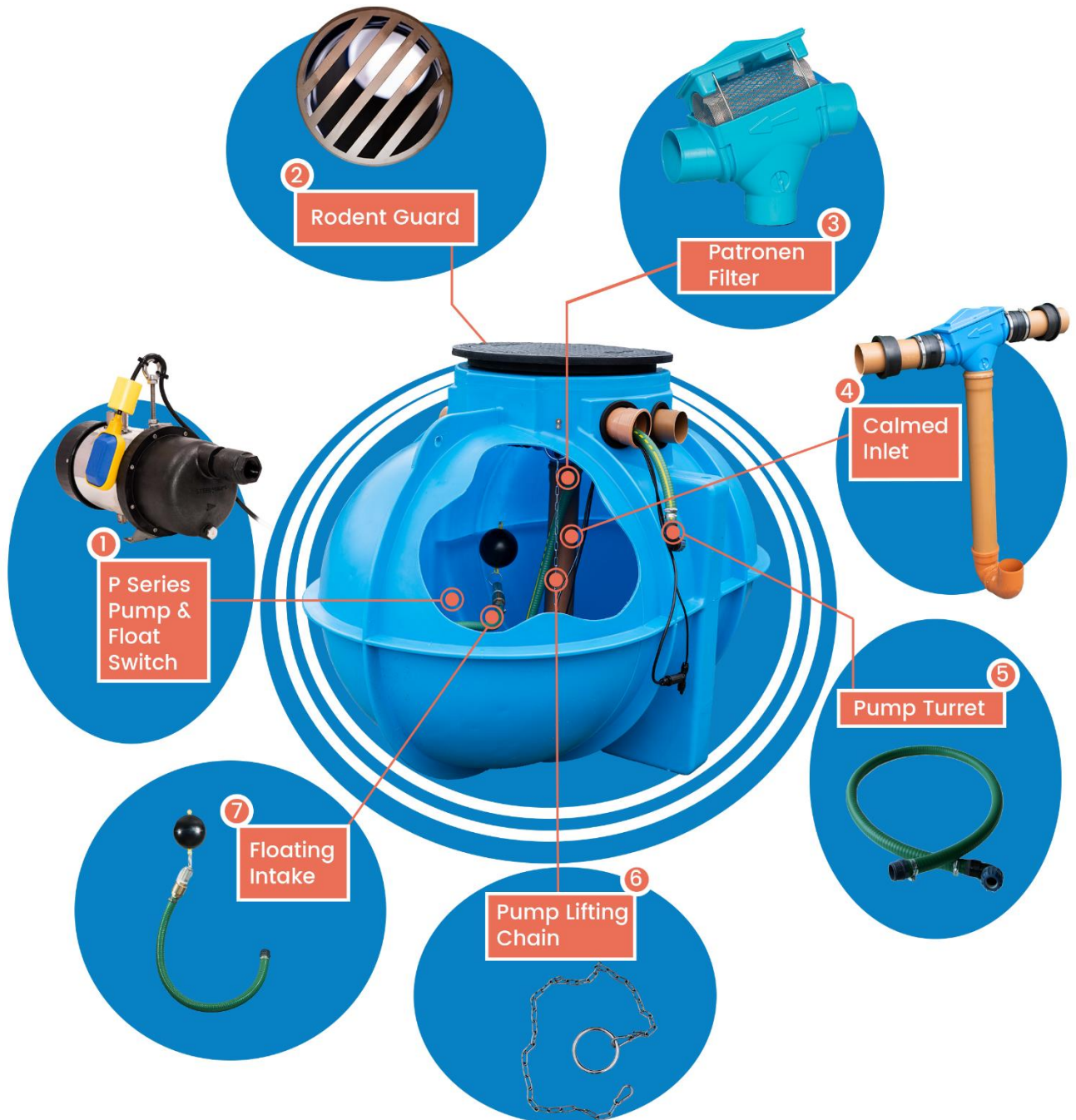

Installation sequence for the Garden Premium system ...

25. See parts descriptions below:

1. The Steelpumps X – AJE80P is a stainless steel submersible water pump c/w integral float switch to protect from dry running. This is an automatic pressure sensing pump supplied separately and is lowered into the tank base via a stainless steel chain (provided) for ease of raising and lowering during routine maintenance. See above pump spec for further details
2. Same as the Garden Eco system
3. Same as the Garden Eco system
4. The calmed inlet is supplied as pre-fitted. This removes the kinetic energy from the incoming water reducing any stirring up effect. It also introduces fresh and highly oxygenated water into the bottom of the tank thereby reducing stagnation and ensuring water quality is kept high
5. Same as the Garden Eco system
6. This is the stainless steel lifting chain which is supplied separately and is fitted to the pump before lowering into the tank. The handle part hooks onto a pre-fitted stainless steel hook on the inside of the tank neck
7. The floating intake system ensures that the water is drawn from just below the top level of water. This is commonly regarded as always being the best quality of water available in the tank. The intake system also has a strainer ensuring any finer particles are removed before the water reaches the pump

The lid is shown here but is an optional extra.

Home & Garden Direct Pressure system ...

The picture below shows the main parts supplied with this system kit. Some of these parts may already be pre-fitted to your tank. This picture can be used to identify and check the availability of all the parts on delivery:

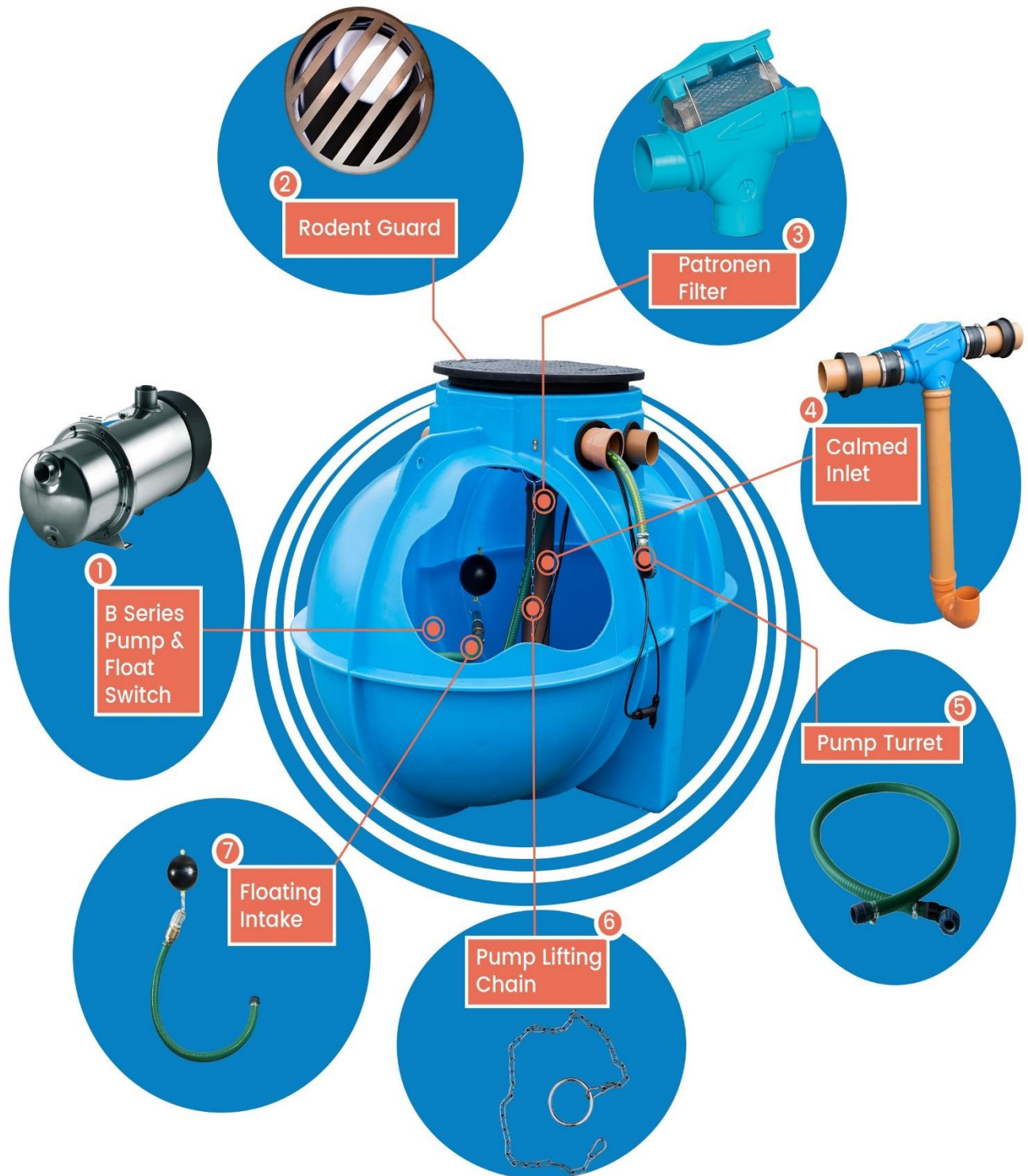

Installation sequence for the Home & Garden Direct Pressure system ...

26. See parts descriptions below:

1. The Steelpumps X – AJE80B is a stainless steel submersible water pump. This is an automatic pressure sensing pump that is supplied separately and is lowered into the tank base via a stainless steel chain (provided) for ease of raising and lowering during routine maintenance. See above pump spec for further details
2. Same as the Garden Premium system
3. Same as the Garden Premium system
4. Same as the Garden Premium system
5. Same as the Garden Premium system
6. Same as the Garden Premium system
7. Same as the Garden Premium system

27. Also included in this kit is the Puratank Mains Water Top-UP Set Compact. Please see the operating and set up instructions as below:

Product Description ...

Automatic mains water top-up for rainwater tanks with leak detection feature and pump dry-run protection.

This unit is primarily designed to work with automatic pumps, i.e. pumps which are self- controlling by having a pressure switch controller built into the pump. If you are in any doubt, please consult a professional. Your supplier can advise you.

You will need to Commission an automatic pump, which needs to feed into a water-tight delivery network. If you are in any doubt, please consult a professional. Experienced Rainwater Harvesting (RWH) commissioning professionals are available to assist you. Failure to commission an automatic pump may invalidate your warranty. A guide to commissioning is available as an Appendix to this document. A pressure vessel will prolong the life of automatic pumps.

This is a reliable electronic controller that will give decades of trouble-free service, once correctly installed.

Component Listing ...



1. Tundish with Steel Wall Bracket. DN 40 Overflow. DN 50 Outlet
2. Solenoid Valve
3. Control Unit Module
4. Level Probe, 15m standard
5. Lever Ball Valve, for isolating mains water supply

In addition, there is a “Schuko” (European) Mains Plug. This is supplied in order to allow you to connect any pump to the European style mains socket on the front of the Unit.

Handling and Storage, Pre-installation ...

- Do not leave the Control Unit or solenoid valve outdoors in the rain. They are not IP68 waterproof. Do not store or use in a location subject to freezing temperatures. This may include some outbuildings and uninsulated loft spaces.
- This is not an armoured or heavy-duty appliance, it will not survive impact and drops, crushing, etc. Do not leave on the floor. If damaged do not use it.
- Do not store with or upon cement, sand, plaster, etc. These materials will corrode the circuit board (and cause cosmetic damage).

Installation ...

Site Selection for the Controller Unit

We recommend installation be carried out by a qualified electrician.

The Control Unit and Solenoid Valve must be mounted indoors in a dry place. Do not install in a location subject to freezing temperatures.

It can be wall mounted using the supplied fittings.

NOTE: It is not a waterproof unit. DO NOT install in a tank turret.

We strongly recommend wiring the unit on a dedicated circuit, protected by a 10A Type C circuit protective device, in accordance with current best practice and regulatory requirements as defined by BS 7671, current IEE wiring regulations, and Part P of Building Regulations (where applicable). If in any doubt consult a qualified electrician.

There are a wide variety of pumps supplied in the UK rainwater market, some with 2 pin “Schuko”, and some with 3 pin UK plugs. A 2 pin “Schuko” plug can plug directly into the plug socket on the face of the unit. If your pump has a 3 pin UK plug there are two options available.

- Change the pump’s plug to a 2 pin Schuko plug (one is supplied with this kit).
- Use an earthed 2 pin Schuko to 3 pin UK socket adapter to plug into the Control Unit’s pump socket (not supplied).

SAFETY NOTE – European style Schuko plugs are not protected with a fuse, therefore it is vital the controller is installed on a 10A fused outlet to protect both the pump and controller.

If in any doubt you MUST consult a qualified electrician.

The Tundish and bracket assembly ...

The Tundish acts as a Type AA air gap to comply with BS EN 13076: Devices to prevent pollution by backflow of potable water. The Tundish itself and its’ ½” feed nozzle are both freely rotatable in the wall mounting bracket.

Install the Tundish so that the potable water feed can gravity flow freely into the tank. Check the rate of delivery of potable water does not exceed the capacity of the connected hose/pipework to reach the tank at your site, without backing up. This is part of the Commissioning of your rainwater harvesting system installation process.

The Tundish outlet to the tank (Nominal OD 47mm, ID 39mm) can be connected using 2” hose or with a 50mm MDPE Compression fitting, usually reducing to 32mm minimum, or using Waste Pipe at 50mm.

Note the Tundish has an optional overflow. This is recommended and particularly useful if the top-up feed pipework to the underground tank gets blocked, as it will then likely prevent flooding of the room where the Controller is located. The overflow can be connected with a Universal Waste Adapter. (Product Code AC.WB.5000411UWC).

The Level Probe, a Conductivity Probe ...



The supplied conductivity Level Probe is used as a minimum water level detector in the rainwater tank. The standard length of cable supplied is 15m. This can be extended to order, up to 100m. It carries a very low voltage/current.

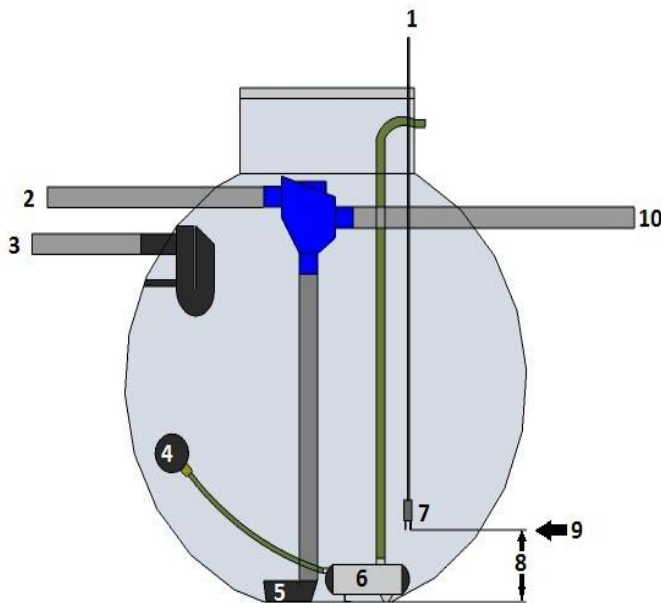

1	To Control Unit (from level probe)
2	Water From Roof
3	Max Water Level (overflow)
4	Floating Intake
5	Calmed Inlet
6	Pump
7	Level Probe set 200mm above pump
8	Approx. 0.3-0.4 m (guide only)
9	Minimum Water Level
10	Sewer Connection

Fix the Level Probe in the tank so that it is suspended approximately 0.3 to 0.4 metres above the bottom, depending on the shape of the tank and position of pump inlet. It should be positioned to ensure there is no risk of cavitation or air entrainment to the pump inlet. If in doubt you **MUST** consult an approved and qualified plumber. The height of the Level Probe determines the minimum water level of the tank at which the pump will run.

The Level Probe works by conductivity. When the Level Probe's contacts are immersed in water a circuit is completed and the control unit detects this. When the prongs of the probe come out of the water, topping up is activated.

Note: The Level Probe's length of cable can be extended to a maximum of 100m.

OPERATIONAL ADVICE NOTES – *Ensure that the tank is entirely free of debris before installing a pump and this controller. Sand, grit, cement and even plastic swarf from manufacturing and other debris will quickly clog any filters and may damage the pump's internal parts and the pump's impellers, prematurely shortening the operational life of the system, and invalidate pump and other component warranties. The potable feed pipework to the solenoid must also be clear and free of debris.*

Maintenance Advice – It is good practice to gently clean the probe at intervals of three years or whenever checking the tank.

Control Unit Operation ...

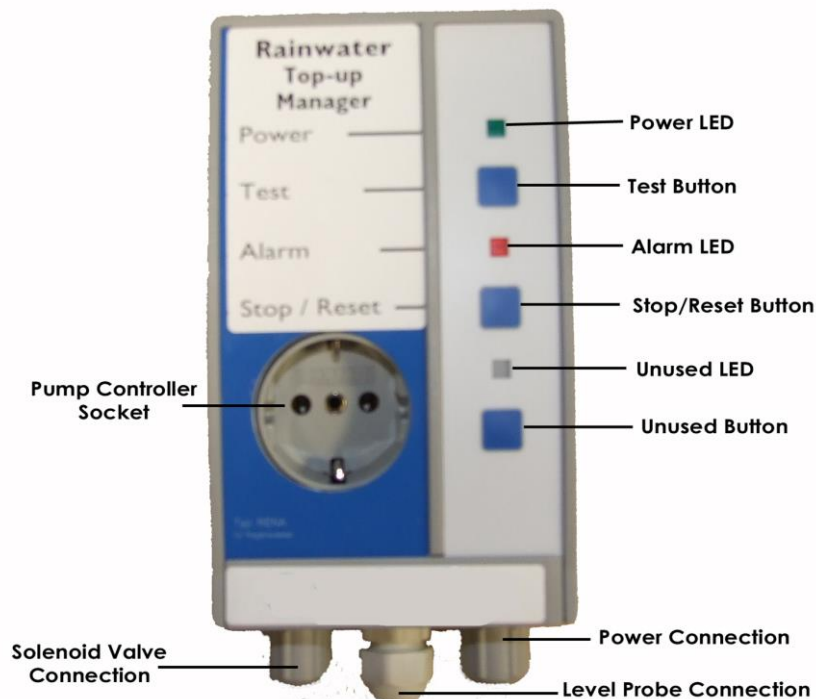

Test button: Pressing this when the Solenoid Valve is closed will momentarily open and close the Solenoid Valve.

Stop/Reset button: Closes the solenoid valve and shuts off power to the pump. The Alarm LED will flash.

A second press will reset the controller to its usual working state.

When the Control Unit is powered up:

High Water Level: If the Level Probe is immersed in rainwater, (i.e. below the rainwater level in the tank) then the green LED remains on, there is power to the pump socket (so a connected pump will then run) and the solenoid valve is closed (i.e. not topping up).

Low Water Level: If the rainwater level falls below the Level Probe a top-up cycle will begin. The green LED flashes and the Solenoid Valve opens to allow mains water to flow via the Tundish and so into the rainwater tank. During the top-up cycle the pump will be turned off (power to the pump is isolated during topping up).

Once the water level reaches the Level Probe again the pump is re-enabled, and so allowed to run. The solenoid valve will remain open for a further ONE minute before closing. The top-up cycle is now complete and the green LED changes from flashing to solid.

Self Maintenance: The Control Unit will momentarily open and close the Solenoid Valve three times a week to prevent blockages. This process takes place automatically.

Safety Shutdown: During a top-up cycle, if the water level in the tank has not reached the level probe after 30 minutes of topping up, the unit will shut off the pump and close the solenoid. The red alarm LED lights to indicate that there is one or more of: 1. a leak or blockage in the delivery pipework feeding to the tank, 2. a failure of the tank itself, or 3. a problem with the solenoid valve.

LED Indicators ...

Green - Solid	Normal Operation. Solenoid Valve closed. Pumps runs as usual. Water level sufficient.
Green - Flashing	Top-up cycle in progress. Solenoid Valve open (topping up). Pump is disabled (switched off) during top-up.
Red - Solid	Safety shutdown. Top up failed.
Red - Flashing	Control Unit stopped manually (stop/reset button has been pressed by an operator).

Internal Jumper Settings ...

This can be adjusted to increase the duration of the top-up cycle, and should be set by Puratank in advance, or otherwise adjusted by a qualified electrician or instrumentation technician.

The power supply MUST be disconnected before opening the Control Unit, there are hazardous voltages inside.

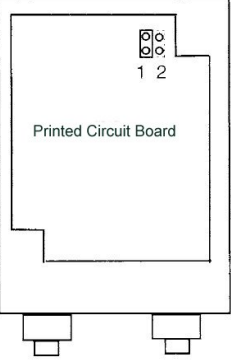
 <p>Printed Circuit Board</p>	<p>For larger tanks and flow rates the jumper can be moved from the default position 1, to position 2. This position tops up much more water into the tank. (see below).</p> <p>In position 2 the pump shut-off delay and alarm delays are also increased accordingly.</p> <p>If in any doubt please consult a qualified electrician or electronic technician.</p>
---	--

	<p>Attention! The Control Unit must only be opened when it has been ensured that there is no power to the unit.</p>
---	--

Jumper Setting	Delay before pump shut-off during top-up	Top-up duration after level probe is reached	Safety Shutdown delay
1	15 sec	1 min	30 min
2	10 min	20 min	45 min

Jumper setting 1: The pump will turn off 15 seconds after the beginning of a top-up cycle. The Solenoid Valve will close 1 minute after the water level reaches the Level Probe. If the water level doesn't reach the Level Probe within 30 minutes the unit alarms.

Jumper setting 2: The pump will turn off 10 minutes after the beginning of a top-up cycle. The Solenoid Valve will close 20 minutes after the water level reaches the Level Probe. If the water level doesn't reach the Level Probe within 45 minutes the unit alarms.

Troubleshooting Guide: an “At Site Level” Fault Finder ...

Symptom	Possible Faults	Solution
Solid Red LED – Controller has alarmed and shut down.	Solenoid is blocked	Press Reset, then test solenoid by pressing Test button. If solenoid clicks but no water flows, check the supply pipework and flexi-hose for blockages. If supply is clear but solenoid does not function, replace solenoid (call technical support).
	Solenoid has failed.	If solenoid does not click, check wiring from solenoid to controller for possible damage. If OK replace solenoid (call Puratank Technical support).
	Solenoid functions normally, tundish overflows	The supply pipe from tundish to tank is blocked. Clear blockage and retest.
	Solenoid functions normally, tundish does not overflow but tank does not fill.	Check tundish to tank pipework by visually looking for top-up water entering the tank. If no water is present, suspect failure in pipework. If water is present suspect tank failure.
Flashing red LED – Controller has been stopped Manually.	No fault.	Press the stop/reset button to reset the controller.
Top-up cycle is too frequent causing pump to be shut off during demand for water.	Too small a top-up time is selected.	Follow the Internal Jumper Settings instructions to change the jumper to position 2. Consult a qualified electrician before opening the Control Unit. If in any doubt please consult a qualified electrician or electronic technician.
Top-up cycle activates often, even when no water is drawn on demand.	Possible tank failure or fault (leak) in supply pipes from pump.	Shut down controller and pump and check tank water level periodically (during dry weather). If water level drops, suspect tank failure. Otherwise switch on controller and pump and check for leaks in outlet pipes from pump, and possible leaks of toilet float valves, etc. Consider a larger pressure vessel. Consult a professional adviser.

Symptom	Possible Faults	Solution
Controller does not function (no lights).	Internal fuse failure.	Have the controller's internal fuses checked by a qualified electrician and replaced if necessary. If the unit fails again, contact your supplier for replacement. If in doubt please consult a qualified electrician or electronic technician.
	Controller or associated wiring has tripped the mains circuit breaker or RCD.	Have the supply circuit checked by a qualified electrician. Check circuit breaker is of a suitable rating (10A Type B recommended), also test wiring insulation and earth. If the supply circuit is proved to have no fault, contact your supplier for replacement.
Pump does not run, top-up and other functions seem ok.	Pump failure.	Unplug the pump and test separately.
	Controller Damaged.	The control unit can supply up to 10A at 240v to the pump. It may be damaged if this specification is exceeded.
For all other faults.	Contact your system supplier.	If your system supplier is no longer trading, you may consult Puratank.

Full Technical Specification ...

Control Unit

Dimensions (W x H x D):	97mm x 163mm x 62mm
Weight:	0.5 kg
Supply voltage:	AC 230-240 V 50 Hz
Nominal Power Consumption:	5w (excluding pump)
Internal fuse:	32 mA
Pump power outlet socket:	AC 230-240 V, max. 10 A (fused)
Mains Plug Fuse:	T 10 A
Operating Temperature Range Ambient:	0 °C to +40 °C
Electrical Protection class:	II (DIN 57 700)
Ingress Protection:	IP 20 (EN 60529)
Noise immunity:	According to EN 50082-1
Noise suppression:	According to EN 50081-1

Level Probe

Supply voltage:	AC 6 V
Probe current:	1.2 mA
Cable length:	15m (max. 30m)
Dimensions of probe (L x Ø):	87mm x 30mm
Weight:	0.2 kg
Principle of operation:	Conductivity
Medium:	Clean water

Solenoid Valve

Dimensions (W x H x D):	95mm x 80mm x 100mm
Weight:	0.5 kg
Supply voltage:	AC 230-240 V 50 Hz
Power consumption:	max. 5.5 VA
Connection cable:	3m
Mounting position:	Any
Medium:	Clean water
Maximum pressure:	12 bar
Flow rate at 4 bar inlet pressure and open outlet:	approx. 50 l/min
Connection:	Inlet: ¾" BSP union nut with in-line filter
Function:	Closed when de-energised
Protection:	IP 56 (EN 60529)
Outlet:	½" BSP female thread

Commissioning

28. Commissioning is the final stage before the system is handed-over to the end-user and is shown to be functioning correctly; commissioning is intended to ensure:

- ⇒ The installation is complete and "Fluidmaster" valves fitted to cisterns (where applicable)
- ⇒ All connections to the mains water top-up system are correct (where applicable)
- ⇒ The pump and associated fittings and cables are correctly positioned in the tank
- ⇒ Pump dry-run protection working
- ⇒ The filter is correctly housed
- ⇒ The mains back-up is functioning (checked as explained above)
- ⇒ The system is holding pressure
- ⇒ There are no leaks or weeps
- ⇒ The installation and user manuals are present for the end-user
- ⇒ On completion of the commissioning checks, the in-tank filter is to be lined with polythene to prevent rainwater entering the tank before the property is sold and occupied

29. Bearing in mind that by this stage much of the installation work may no longer be visible, there is the potential for tradesmen to satisfactorily test the system at the completion of their work, but for it to subsequently malfunction due to hidden defects arising during installation.

30. Typical examples of poor workmanship that are likely to cause subsequent operational problems, include:

- ⇒ Failure to fit leaf-guards to down-pipes, leading to a blockage of the pre-tank filter
- ⇒ Underground pipes being poorly joined, leading to the ingress of ground-water
- ⇒ Tank neck & lid assemblies being poorly sealed, again leading to the ingress of ground-water
- ⇒ Site dust/soil and debris being allowed to enter into the storage tank or drainage runs leading to poor water quality and premature pump failures
- ⇒ Failure to keep delivery pipes sealed during pull-through, leading to site debris gaining entry to the pipe

- ⇒ Surface water being allowed to enter the tank for a prolonged period (ie in excess of 20-days) and stagnating before the system enters regular service
31. This places a premium on good workmanship and supervision during the installation process to ensure:
- ⇒ No debris is allowed to enter the tank or any of the pipe-work
 - ⇒ The tank and pipe-work are undamaged, and all connections are water-tight
 - ⇒ Invert levels are correct, and backflow prevention valves are fitted in high water-table installations, or if the overflow is connected to a storm-drain
 - ⇒ A filter cover is fitted until immediately before the system is handed-over to the end-user

Using the system

Handing-over ...

32. The system is now ready to be signed-off by the commissioning tradesman, and handed-over to the client, covering all relevant points such as:
- ⇒ Demonstrating use of the equipment, and its controls
 - ⇒ Explaining any system limitations/constraints
 - ⇒ Identifying the major components, their inter-relationship and normal function
 - ⇒ Explaining maintenance requirements
 - ⇒ Running through the fault-finding guide
 - ⇒ Providing system support contact information
 - ⇒ The need to remove the filter seal when the property is about to be occupied
 - ⇒ Providing the Safety File copies of the O&M Manual (commercial systems) or Installation & User Manuals (domestic systems)



Arrangements also need to be in place to ensure that the end-user receives an equally comprehensive hand-over.

Safety & access ...

33. Proper risk assessments are to be made whenever maintenance work is undertaken on the system.
34. For most of the checks to be made during routine maintenance and repair activities, electrical power will need to be “on”, and all system stop-cocks “open”; however, care must be taken to:
- ⇒ Isolate electrical power when appropriate to the work being undertaken
 - ⇒ Close any stop-cock and isolate the pump when plumbing connections need to be broken (during removal and cleaning of in-line strainer, for example); re-made connections are to be properly re-taped with PTFE, where appropriate



Routine maintenance ...

35. The routine maintenance requirements of the system is limited to a quarterly check of:

- ⇒ Whether the user has experienced any problems or unusual symptoms
- ⇒ The correct operation of services, including dry-run protection & mains top-up
- ⇒ No signs of leaks or weeps
- ⇒ No sign of wiring deterioration
- ⇒ Correct operating pressure
- ⇒ Gutters clean, leaf filters in place, and pre-tank and in-line filters removed/cleaned
- ⇒ Good water quality in the main storage tank, and to services
- ⇒ No “tide-mark” in the neck of the tank to indicate over-filling (ie overflow failure)
- ⇒ Tank contents matches contents gauge (if present) and the weather/usage pattern

Fault finding ...

36. Helpful information is provided at www.atlantistanks.co.uk under the Puratank section

37. Generic reasons why systems may malfunction include:

- ⇒ **No power** supply to the system; *check fuses etc*
- ⇒ **No water** in the tank; *check pre-tank filter is clean and operation of the back-up*
- ⇒ **Pump inoperative**; *may need replacing or re-setting (power “off”/“on”)*
- ⇒ **Incorrect top-up** operation; *check float-valve/sensor suspension and operate manually*
- ⇒ **Component failures**
- ⇒ **Pump “hunting”** (when services not being used); *weep or leak on the delivery side of the system (will shorten pump life and may cause it to fault-out)*
- ⇒ **Continuous pumping** (but no pressure to services); *delivery pipe split or disconnected from the pump (system needs to be switched-of as soon as detected to protect the pump and avoid energy waste)*

Water quality ...



38. The water appearing in toilet bowls should look clean/clear; as noted above, checking the quality of the water in the main storage tank is one of the requirements of periodic maintenance because:

- ⇒ Poor quality water in the tank will provide poor quality water to the services which is unacceptable
- ⇒ It may be an indicator of pre-tank filtration issues, which may additionally affect its efficiency at harvesting water
- ⇒ Poor quality water may damage the pump, or reduce pump life

39. In the event of water-quality issues arising, potential causes include:

- ⇒ System continuing to harvest rainwater which remains unused during the period between installation and occupancy (*avoided by sealing the filter until the system is ready for use*)





- ⇒ Foreign matter being allowed to enter the tank during the construction process (*which must be avoided*)
- ⇒ Ground-water ingress (*avoided by sealing properly the neck shaft and all underground connections during installation*)
- ⇒ Back-flow from under-performing soak-aways (*avoided by installation of one-way valves on the over-flow*)

Sales terms & conditions ...

40. Please see below:

Terms & Conditions

This page (together with the documents referred to on it) tells you the terms and conditions on which we supply any of the products ('Products') listed on our website to you. Please read these terms and conditions carefully before ordering any Products from our site. You should understand that by ordering any of our Products, you agree to be bound by these terms and conditions.

You should print a copy of these terms and conditions for future reference.

1. AVAILABILITY

Our site is only intended for use by people resident in the United Kingdom. We do not accept orders from any person outside the United Kingdom.

2. YOUR STATUS

By placing an order through our site, you confirm that:

- (a) You are legally capable of entering into binding contracts;
- (b) You are a limited liability company, LLP, partnership or a natural person and (if you are a natural person) you are at least 18 years old;
- (c) You are resident in the United Kingdom; and
- (d) You are accessing our site from the United Kingdom.

We rely on these statements by you in entering an agreement with you for sale of any Product.

3. HOW THE CONTRACT IS FORMED BETWEEN YOU AND US

3.1 After placing an order, you will receive an e-mail from us acknowledging that we have received your order. Please note that this does not mean that your order has been accepted. Your order constitutes an offer to us to buy Products. All orders are subject to acceptance by us, and we will confirm any such acceptance to you by sending you an e-mail that confirms that the Products have been dispatched ('the Dispatch Confirmation'). The contract between us ('Contract') will only be formed when we send you the Dispatch Confirmation.

3.2 The Contract will relate only to those Products whose dispatch we have confirmed in the Dispatch Confirmation. We will not be obliged to supply any other Products which may have been part of your order until the dispatch of such Products has been confirmed in a separate Dispatch Confirmation.

4. CONSUMER CANCELLATION RIGHTS

4.1 This clause applies only if you are contracting as a consumer ('Consumer') and the Contract is a distance or off-premises contract.

4.2 For the purpose of this clause, the terms Consumer, distance contract and off-premises contracts have the meanings provided by Regulations 4 and 5 of The Consumer Contracts (Information, Cancellation and Additional Charges) Regulations 2013.

4.3 If you are contracting as a Consumer and the Contract is a distance or off-premises contract, you may cancel the Contract at any time within fourteen days, beginning on the day after you received the Product. In this case, you will receive a full refund of the price paid for the Product in accordance with our refunds policy (set out in clause 8 below).

4.4 To cancel a Contract, you must inform us in writing. We will then arrange for the collection of the Products, which must be returned in the same condition in which you received them. You have a legal obligation to take reasonable care of the Products while they are in your possession. If you fail to comply with this obligation, we may have a right of action against you for compensation.

4.5 In entering into this Contract you agree that you will be responsible in the event of cancellation for payment of any costs we incur in the collection of the Products from you. Those costs will be limited to the equivalent of 10% of the total price paid for the Products and will be deducted from any refund due to you.

5. AVAILABILITY AND DELIVERY

Your order will be fulfilled by the delivery date set out in the Dispatch Confirmation or, if no delivery date is specified, then within 30 days of the date of the Dispatch Confirmation, unless there are exceptional circumstances.

6. RISK AND TITLE

6.1 The Products will be at your risk from the time of delivery.

6.2 Ownership of the Products will only pass to you when we receive full payment of all sums due in respect of the Products, including delivery charges.

7. PRICE AND PAYMENT

7.1 The price of any Products will be as quoted on our site from time to time, except in cases of obvious error.

7.2 These prices include VAT and delivery costs.

7.3 Prices are liable to change at any time, but changes will not affect orders in respect of which we have already sent you a Dispatch Confirmation.

7.4 It is always possible that, despite our best efforts, some of the Products listed on our site may be incorrectly priced. We will normally verify prices as part of our dispatch procedures so that, where the Products' correct price is less than our stated price, we will charge the lower amount when dispatching the Products to you. If the Products' correct price is higher than the price stated on our site, we will normally, at our discretion, either contact you for instructions before dispatching the Products, and/or reject your order and notify you of such rejection.

7.5 We are under no obligation to provide the Products to you at the incorrect (lower) price, even after we have sent you a Dispatch Confirmation, if the pricing error is obvious and unmistakable and could have reasonably been recognised by you as a mis-pricing.

7.6 We accept payment by credit and debit card, Sage Pay, and Paypal.

8. OUR REFUNDS POLICY

8.1 When you return a Product to us:

(a) because you have cancelled the Contract between us within the cooling-off period (see clause 4.3 above), we will process the refund due to you as soon as possible and, in any case, within 30 days of the day you have given notice of your cancellation. In this case, we will refund the price of the Products in full, including the cost of sending the item to you.

(b) for any other reason (for instance, because you claim that the Product is defective), we will examine the returned Products and will notify you of your refund via e-mail within a reasonable period of time. We will usually process the refund due to you as soon as possible and, in any case, within 30 days of the day we confirmed to you via e-mail that you were entitled to a refund for the defective Products. Products returned by you because of a defect will be refunded in full, including a refund of the delivery charges for sending the item to you and the cost incurred by you in returning the item to us.

8.2 We will usually refund any money received from you using the same method originally used by you to pay for your purchase.

9. WARRANTY / OUR LIABILITY

9.1 We warrant to you that any Products purchased from us through our site are of satisfactory quality and reasonably fit for all the purposes for which products of the kind are commonly supplied.

9.2 We warrant that at the time of delivery the Products will be EN/CE approved and compliant with all applicable laws, including ADR and The Carriage of Dangerous Goods and Use of Transportable Pressure Equipment Regulations 2009. Any requirement to re-test the Products following delivery will be your responsibility.

9.3 We guarantee that on delivery and for a period of twelve months (or, if longer, any other period shown in our warranty booklet and/or on our invoice for the Products sold to you and/or in our brochure and/or our site as at the date of your order for Products) from delivery, the Products shall be free from material defects. However, this guarantee does not apply in the circumstances described in clause 9.4.

9.4 This guarantee does not apply to any defect in the Products arising from:

- (a) fair wear and tear;
- (b) wilful damage, abnormal storage or working conditions, accident, negligence by you or by any third party;
- (c) if you fail to operate or use the Goods in accordance with the user instructions;
- (d) any alteration or repair by you or by a third party; and
- (e) any specification provided by you.

This guarantee is in addition to, and does not affect, your legal rights in relation to Products which are faulty or not as described.

9.5 Our liability for losses you suffer as a result of us breaking this agreement is limited to the purchase price of the Products you purchased and we do not accept any liability for consequential losses or (subject to clause 9.3) any losses that are a foreseeable consequence of us breaking the agreement. Losses are foreseeable where they could be contemplated by you and us at the time your order is accepted by us.

9.6 This does not include or limit in any way our liability:

- (a) for death or personal injury caused by our negligence or the negligence of our employees, agents or subcontractors;
- (b) for defective products under the Consumer Protection Act 1987;
- (c) for fraud or fraudulent misrepresentation; or
- (d) for any matter for which it would be unlawful for us to exclude, or attempt to exclude, our liability.

9.7 We are not responsible for indirect losses which happen as a side effect of the main loss or damage including but not limited to:

- (a) loss of income or revenue
- (b) loss of business
- (c) loss of profits or contracts
- (d) loss of the content of any tank
- (e) loss of anticipated savings; or
- (f) loss of data

provided that this clause 9.6 shall not prevent claims for loss of or damage to your tangible property that fall within the terms of clause 9.1 or clause 9.3 or any other claims for direct financial loss that are not excluded by any of categories (a) to (f) inclusive of this clause 9.7.

10. WRITTEN COMMUNICATIONS

Applicable laws require that some of the information or communications we send to you should be in writing. When using our site, you accept that communication with us will be mainly electronic. We will contact you by e-mail or provide you with information by posting notices on our website. For contractual purposes, you agree to this electronic means of communication and you acknowledge that all contracts, notices, information and other communications that we provide to you electronically comply with any legal requirement that such communications be in writing. This condition does not affect your statutory rights.

11. NOTICES

All notices given by you to us must be given to us at sales@atlantistanks.co.uk. We may give notice to you at either the e-mail or postal address you provide to us when placing an order, or in any of the ways specified above. Notice will be deemed received and properly served immediately when posted on our website, 24 hours after an e-mail is sent, or three days after the date of posting of any letter. In proving the service of any notice, it will be sufficient to prove, in the case of a letter, that such letter was properly addressed, stamped and placed in the post and, in the case of an e-mail, that such e-mail was sent to the specified e-mail address of the addressee.

12. TRANSFER OF RIGHTS AND OBLIGATIONS

12.1 The Contract between you and us is binding on you and us and on our respective successors and assigns.

12.2 You may not transfer, assign, charge or otherwise dispose of the Contract, or any of your rights or obligations arising under it, without our prior written consent.

12.3 We may transfer, assign, charge, sub-contract or otherwise dispose of the Contract, or any of our rights or obligations arising under it, at any time during the term of the Contract.

13. EVENTS OUTSIDE OUR CONTROL

13.1 We will not be liable or responsible for any failure to perform, or delay in performance of, any of our obligations under a Contract that is caused by events outside our reasonable control ('Force Majeure Event').

13.2 A Force Majeure Event includes any act, event, non-happening, omission or accident beyond our reasonable control and includes in particular (without limitation) the following:

- (a) Strikes, lock-outs or other industrial action.
- (b) Civil commotion, riot, invasion, terrorist attack or threat of terrorist attack, war (whether declared or not) or threat or preparation for war.
- (c) Fire, explosion, storm, flood, earthquake, subsidence, epidemic or other natural disaster.

- (d) Impossibility of the use of railways, shipping, aircraft, motor transport or other means of public or private transport.
- (e) Impossibility of the use of public or private telecommunications networks.
- (f) The acts, decrees, legislation, regulations or restrictions of any government.

13.3 Our performance under any Contract is deemed to be suspended for the period that the Force Majeure Event continues, and we will have an extension of time for performance for the duration of that period. We will use our reasonable endeavours to bring the Force Majeure Event to a close or to find a solution by which our obligations under the Contract may be performed despite the Force Majeure Event.

13.4 We may have to cancel your order if stock is unavailable. If this happens:

- (a) We will promptly contact you to let you know.
- (b) If you have made any payment in advance for Products that have not been delivered to you we will refund those amounts to you.
- (c) We will not charge you anything further and you will not have to make any payment to us.

14. WAIVER

14.1 If we fail, at any time during the term of the Contract, to insist upon strict performance of any of your obligations under the Contract or any of these terms and conditions, or if we fail to exercise any of the rights or remedies to which we are entitled under the Contract, this shall not constitute a waiver of such rights or remedies and shall not relieve you from compliance with such obligations.

14.2 A waiver by us of any default shall not constitute a waiver of any subsequent default.

14.3 No waiver by us of any of these terms and conditions shall be effective unless it is expressly stated to be a waiver and is communicated to you in writing in accordance with clause 13 above.

15. SEVERABILITY

If any of these terms and Conditions or any provisions of a Contract are determined by any competent authority to be invalid, unlawful or unenforceable to any extent, such term, condition or provision will to that extent be severed from the remaining terms, conditions and provisions which will continue to be valid to the fullest extent permitted by law.

16. ENTIRE AGREEMENT

16.1 These terms and conditions and any document expressly referred to in them represent the entire agreement between us in relation to the subject matter of any Contract and supersede any prior agreement, understanding or arrangement between us, whether oral or in writing.

16.2 We each acknowledge that, in entering into a Contract, neither of us has relied on any representation, undertaking or promise given by the other or be implied from anything said or written in negotiations between us prior to such Contract except as expressly stated in these terms and conditions.

16.3 Each of us agrees that the only rights and remedies available to us arising out of or in connection with a Representation shall be for breach of contract as provided in these terms and conditions.

16.4 Nothing in this clause shall limit or exclude any liability for fraud.

17. OUR RIGHT TO VARY THESE TERMS AND CONDITIONS

17.1 We have the right to revise and amend these terms and conditions from time to time.

17.2 You will be subject to the policies and terms and conditions in force at the time that you order products from us, unless any change to those policies or these terms and conditions is required to be made by law or governmental authority (in which case it will apply to orders previously placed by you), or if we notify you of the change to those policies or these terms and conditions before we send you the Dispatch Confirmation (in which case we have the right to assume that you have accepted the change to the terms and conditions, unless you notify us to the contrary within seven working days of receipt by you of the Products).

18. LAW AND JURISDICTION

Contracts for the purchase of Products through our site and any dispute or claim arising out of or in connection with them or their subject matter or formation (including non-contractual disputes or claims) will be governed by English law. Any dispute or claim arising out of or in connection with such Contracts or their formation (including non-contractual disputes or claims) shall be subject to the non-exclusive jurisdiction of the courts of England and Wales.

19. GENERAL DATA PROTECTION REGULATION

The General Data Protection Regulation ('GDPR') came into force on 1 May 2018 and sets out how we must process data that we hold about you. We refer you to the GDPR Fair Processing Notice on our site for further details.

20. INFORMATION ABOUT US

Portafuel, Storafuel, Puratank, Alltank and Easytank are trading names of Atlantis Tanks Group Ltd (company number: 09955291) whose registered address is Legend House, Station Road, Ferryhill, England, DL17 0BP. Details of this company can be found at www.atlantistanks.co.uk.